

DPS-V55/V55M

SERVICE MANUAL

US Model
Canadian Model

DPS-V55

AEP Model

UK Model

DPS-V55M



Photo: DSP-V55

SPECIFICATIONS

A/D Converter 20 bit resolution

D/A Converter 20 bit resolution

Sampling
Frequency 48 kHz

Input (rear panel)

Jack type	reference input level	maximum input level	input impedance	circuit type
PHONE	-10 dBu or +4 dBu	+20 dBu	More than 45 kilohms	unbalanced

Input (front panel) (DPS-V55M)

Jack type	reference input level	maximum input level	input impedance	circuit type
XLR/ PHONE	-50 dBu	+10 dBu	10 kilohms	balanced

Output

Jack type	reference output level	maximum output level	load impedance	circuit type
PHONE	-10 dBu or +4 dBu	+10 dBu or +20 dBu	less than 1 kilohm	unbalanced

MIDI Input/Output Jack: 5 pin DIN (IN x 1, OUT/THRU x 1)
OUT/THRU can be set to either OUT or THRU

Frequency Response 20 Hz ~ 22 kHz (+0, -1 dB)

Signal-to-Noise
Ratio Greater than 93 dB

Distortion Less than 0.005% (1 kHz)

Effect Algorithms 45 (4ch: 9, 2ch: 27, Mono-Pair: 9)

Memory Preset 200 locations (numbers 001~200)
User 200 locations (numbers 201~400)

Power Source AC 120 V, 60 Hz (DPS-V55)
AC 230 V, 50/60 Hz (DPS-V55M)

Power Consumption 11 W (120 V) (DPS-V55)
12 W (230 V) (DPS-V55M)

Dimensions 482 x 88 x 290 mm (WxHxD not including
projections)

Mass approx. 3.6 kg

Supplied accessories Operating Instructions (1)
Effect Parameter Guide (1)
Preset Memory Catalog (1)

Design and specifications subject to change without notice.

MULTI-EFFECT PROCESSOR



SONY®

TABLE OF CONTENTS

1. SERVICING NOTES	2
2. GENERAL	5
3. DISASSEMBLY	9
4. TEST MODE	11
5. DIAGRAMS	13
5-1. Printed Wiring Board – MAIN Section –	15
5-2. Schematic Diagram – MAIN Section (1/3) –	17
5-3. Schematic Diagram – MAIN Section (2/3) –	19
5-4. Schematic Diagram – MAIN Section (3/3) –	21
5-5. Printed Wiring Boards – PANEL Section –	23
5-6. Schematic Diagram – PANEL Section –	25
5-7. IC Pin Function Description	28
6. EXPLODED VIEWS	32
7. ELECTRICAL PARTS LIST	34

SAFETY-RELATED COMPONENT WARNING!!

COMPONENTS IDENTIFIED BY MARK \triangle OR DOTTED LINE WITH MARK \triangle ON THE SCHEMATIC DIAGRAMS AND IN THE PARTS LIST ARE CRITICAL TO SAFE OPERATION. REPLACE THESE COMPONENTS WITH SONY PARTS WHOSE PART NUMBERS APPEAR AS SHOWN IN THIS MANUAL OR IN SUPPLEMENTS PUBLISHED BY SONY.

ATTENTION AU COMPOSANT AYANT RAPPORT À LA SÉCURITÉ!

LES COMPOSANTS IDENTIFIÉS PAR UNE MARQUE \triangle SUR LES DIAGRAMMES SCHÉMATIQUES ET LA LISTE DES PIÈCES SONT CRITIQUES POUR LA SÉCURITÉ DE FONCTIONNEMENT. NE REMPLACER CES COMPOSANTS QUE PAR DES PIÈCES SONY DONT LES NUMÉROS SONT DONNÉS DANS CE MANUEL OU DANS LES SUPPLÉMENTS PUBLIÉS PAR SONY.

SECTION 1

SERVICING NOTES

ROM VERSION CHECK

- This system have ROM version check function consequently key set up of when power on.
(No need in open the main body)
 - 1) Press three buttons [ENTER], [EXIT], and [POWER] simultaneously, in the power off.
 - 2) Fluorescent indicator tube indicate ROM version about 1 second, and restart system.

Ver 1.00

UPDATING THE ROM (IC704) VERSION

The ROM version may be updated in order to fix the bugs or add the functions. "All Initialize!!" is displayed and internal data are automatically initialized, if the power is turned on after replacing the ROM. In this case, the user preset data and system data cannot be restored. Please notify the users of this matter.

If the same version ROM was replaced for repair, not for version updating, the data are not initialized unless internal data are damaged.

Nevertheless, to avoid a trouble, it is recommended to save internal data using the Data Filer, etc.

The initial version of the ROM will be Ver.1.00 part No. 8-759-499-74.

Note: Internal data mentioned above are all saved in the IC702 (CY6225LL) when the power is turned off.

REPLACING THE BATTERY

The built-in battery must be replaced, if "Battery Low!" is displayed at the power ON. When the battery was used up completely, internally saved data (system data, user preset data, etc.) are all cleared, and "Ext. RAM Error!" "All Initialize!!" are displayed at the power ON, then the data are initialized to the factory setting automatically. In this case, the user preset data and system data cannot be restored. Please notify the users of this matter. Unless "Ext. RAM Error" "All Initialize!!" are displayed at the power ON, internal data are still saved, and in this case, internal data are kept unchanged if the battery is replaced while the power is turned on.

To avoid a trouble, it is recommended to save internal data using the Data Filer, etc.

This information is given to the users on page 19 of the Operation Manual.

Flexible Circuit Board Repairing

- Keep the temperature of the soldering iron around 270 °C during repairing.
- Do not touch the soldering iron on the same conductor of the circuit board (within 3 times).
- Be careful not to apply force on the conductor when soldering or unsoldering.

Notes on chip component replacement

- Never reuse a disconnected chip component.
- Notice that the minus side of a tantalum capacitor may be damaged by heat.

CAUTION

Danger of explosion if battery is incorrectly replaced.

Replace only with the same or equivalent type recommended by the manufacturer.

Discard used batteries according to the manufacturer's instructions.

ADVARSEL!

Lithiumbatteri-Eksplosionsfare ved fejlagtig håndtering.
Udskiftning må kun ske med batteri
af samme fabrikat og type.
Levér det brugte batteri tilbage til leverandøren.

ADVARSEL

Eksplosjonsfare ved feilaktig skifte av batteri.
Benytt samme batteritype eller en tilsvarende type
anbefalt av apparatfabrikanten.
Brukte batterier kasseres i henhold til fabrikantens
instruksjoner.

WARNING

Explosionsfara vid felaktigt batteribyte.
Använd samma batterityp eller en likvärdig typ som
rekommenderas av apparattillverkaren.
Kassera använt batteri enligt gällande föreskrifter.

VAROITUS

Paristo voi räjähtää, jos se on virheellisesti asennettu.
Vaihda paristo ainoastaan laitevalmistajan suosittelemaan tyyppiin.
Hävitä käytetty paristo valmistajan ohjeiden mukaisesti.

SAFETY CHECK-OUT

After correcting the original service problem, perform the following safety check before releasing the set to the customer: Check the antenna terminals, metal trim, “metallized” knobs, screws, and all other exposed metal parts for AC leakage. Check leakage as described below.

LEAKAGE TEST

The AC leakage from any exposed metal part to earth ground and from all exposed metal parts to any exposed metal part having a return to chassis, must not exceed 0.5 mA (500 microamperes.). Leakage current can be measured by any one of three methods.

1. A commercial leakage tester, such as the Simpson 229 or RCA WT-540A. Follow the manufacturers' instructions to use these instruments.
2. A battery-operated AC milliammeter. The Data Precision 245 digital multimeter is suitable for this job.
3. Measuring the voltage drop across a resistor by means of a VOM or battery-operated AC voltmeter. The “limit” indication is 0.75 V, so analog meters must have an accurate low-voltage scale. The Simpson 250 and Sanwa SH-63Trd are examples of a passive VOM that is suitable. Nearly all battery operated digital multimeters that have a 2 V AC range are suitable. (See Fig. A)

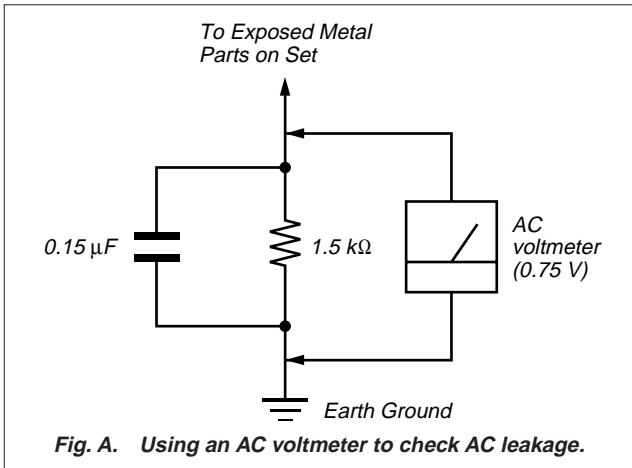

Getting Started

Main Features

The DPS-V55M is a four channels multi-effect processor.

Four channel construction
The DPS-V55M is outfitted with four inputs (and outputs) and can route the input signals in a variety of different ways depending on the chosen effect algorithms and program structures.

Flexible effect algorithms and program structures
The DPS-V55M incorporates a total of 45 different effect algorithms divided into three different types: 4ch, 2ch (stereo), and Mono-Pair. Each effect contains several adjustable parameters and can be easily modified. In addition 2ch and/or Mono-Pair effects can be used in combination within a program, and the program structure can be switched between serial and parallel, allowing you to take full advantage of the four channel construction.

User-friendly operating environment
A primary concern when creating the DPS-V55M, was to provide an intuitive operating system for creative sound control. All effect parameters can be accessed directly using the EDIT PARAMETER buttons.

Large memory banks
In addition to the 200 different preset programs (numbers 001-200) created by musicians and engineers from around the world (preset memory), there is also room for you to store up to 200 of your own original programs in the user memory (numbers 201-400). We've also included a search function so you can recall the programs you need without having to remember their program numbers.

Search function
The search function lets you locate programs you want by specifying the type of effects they contain. (See page 12.)

TAP function
The TAP function lets you adjust certain parameters or trigger certain effects simply by tapping on the ENTER (TAP) button. (See page 15.)

MIDI compatibility
The MIDI interface lets you conduct program change and data save operations. (See page 17.)

How to Use This Manual

These operating instructions describe setup and operating procedures for the DPS-V55M multi-effect processor. Before using this unit we do recommend taking a glance at the "Functional Hierarchy" chart on page 5 and reading "Understanding Effect Algorithms and Program Structures" on page 8 to familiarize yourself with the unit.

"Hooking Up" shows you how to make different kinds of connections between this unit and instruments, mixers, and/or components.

The remaining chapters show you how to operate the unit. Refer to each as necessary.

For specific information regarding the individual effects and parameters, refer to the separate "Effect Parameter Guide." For information regarding the preset memory, refer to the separate "Preset Memory Catalog."

The following icon is used in this manual:
 Indicates hints and tips for making the task easier.

Functional Hierarchy

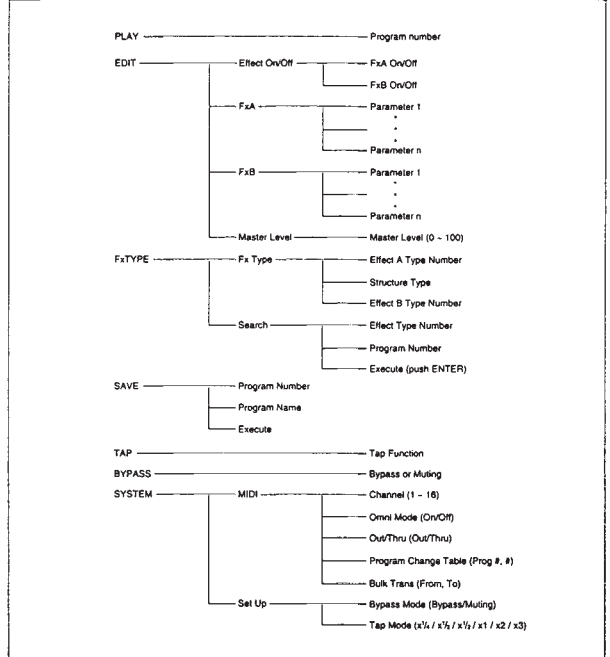

Getting Started

Names and Functions of Parts

Front panel

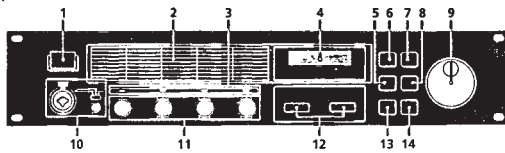

- Power switch**
Press this switch to turn the power on and off. Turning on the power recalls the last used memorized effect and activates play mode automatically.
- Effect algorithm list**
Numbers and names of the 45 available effect algorithms. 01-09 are 4ch algorithms, 10-36 are 2ch algorithms, and 37-45 are Mono-Pair algorithms. (See "Understanding Effect Algorithms and Program Structures" on page 8 for details).
- Input level indicators**
Light green, orange, or red to indicate strength of the signal input to the respective channel (1-4).
Green = -30 to -6 dB; Orange = -6 to -2 dB; Red = clip (greater than -2 dB).
- Display**
Displays various information such as program numbers, program names, effect numbers, effect names, structures, parameter values, etc.
- Fx TYPE (SEARCH) button**
Use to select an effect type or program structure. Also use to search for program by effect type (see page 12).
- BYPASS button**
Press to turn the selected program on or off. (Can also be set to mute the output of the processor, see page 18.)
- SAVE button**
Use this button to save a customized program.
- SYSTEM button**
Use this button to access the MIDI and system setup parameters.
- Rotary encoder**
Use to select program numbers and make adjustments to parameter settings.

- MIC IN jack (DPS-V55M)**
Use to connect a microphone with either an XLR or phone type connector.
Microphone assign switch
Use select which channel the signal input to MIC IN jack will be assigned to.
CH-1: to channel 1 (signals input to the INPUT 1 jack on the rear panel are muted);
CH-1+2: to channels 1 and 2 (signals input to the INPUT 1 and 2 jacks on the rear panel are muted);
REAR: input from the MIC IN jack is muted and only the sound input to the rear inputs (1-4) is processed.
MIC GAIN level adjustment knobs
Turn the knob to the left or right to adjust the input level of the signal input to the MIC IN jack (up to 40 dB).
- INPUT LEVEL adjustment knobs**
Turn the knob to the left or right to adjust the input level of the respective channel (1-4). The input level can be increased up to 12 dB above unity* without clipping.
* When the input and output levels are the same. (On this unit, unity is achieved when the mark on the INPUT LEVEL knob is pointing toward the large index mark (located at approximately 1 o'clock).)
- EDIT PARAMETER (SKIP) buttons**
Use to select the parameter you want to adjust when customizing an effect.
Press both buttons at the same time to skip to another parameter group, see page 14.
- EXIT button**
Press to return to the play mode.
- ENTER (TAP) button**
Use to confirm SAVE operations (etc.). Also use as a trigger, or to set time-variable parameters (see page 15).

Names and Functions of Parts

Rear panel



- LCD CONTRAST knob**
Use to adjust the contrast of the display on the front panel.
- MIDI OUT/THRU terminal**
For sending and/or relaying MIDI command signals from the processor to other components. To switch between OUT and THRU, see pages 17-18.
- MIDI IN terminal**
Input for MIDI command signals. Use a commercially available MIDI cable to connect this terminal to another component's MIDI OUT (or THRU) terminal.
- OUTPUT jacks (1-4)**
Standard output jacks for channels 1, 2, 3, and 4. Connect to an amplifier or mixer (etc.).
Jacks are divided into two groups:
GROUP A (1 (L) and 2 (R))
GROUP B (3 (L) and 4 (R))
Output level selector
Use to set the output level of the OUTPUT jacks to match the input level of the connected equipment. You can select a +4 dBu or -10 dBu output level. This setting effects all jacks (1, 2, 3, and 4).
- INPUT jacks (1-4)**
Standard input jacks for channels 1, 2, 3, and 4. Connect to mixer, CD player, or keyboard (etc.).
Jacks are divided into two groups:
GROUP A (1 (L/MONO) and 2 (R))
GROUP B (3 (L/MONO) and 4 (R))
When inputting a monoaural signal, use the 1 or 3 (MONO) jacks. The signal is sent to both of the channels in the respective group.
Input level selector
Use to set the input level of the INPUT jacks to match the output level of the connected equipment. You can select a +4 dBu or -10 dBu input level. This setting effects all jacks (1, 2, 3, and 4).
- AC power cord**
Connect to an AC power outlet.

Getting Started

Understanding Effect Algorithms and Program Structures

Effect algorithms

This unit contains three types of effect algorithms: 4ch, 2ch, and Mono-Pair.

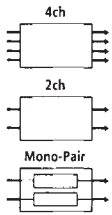

The 4ch effects (algorithms # 01-09) are designed to handle four channels simultaneously. These are also the highest quality effects. Consequently, programs containing these effects can not contain any other effects.

2ch effects (algorithms # 10-36) and Mono-Pair effects (algorithms # 37-45), on the other hand, are designed to handle two channels simultaneously and can be used in various combinations within a program. Each program can contain two 2ch effects, two Mono-pair effects, or one 2ch effect and one Mono-Pair effect.

The 2ch effects are "traditional" stereo effects. Mono-Pair effects are combinations of two parallel mono effects (one for each channel).

Program structures

Each program can contain up to two effects (FxA and FxB) depending on the type of effect selected. If a 2ch or Mono-Pair effects are selected, the program contains two effects (one, or both can be turned off if necessary). When a program contains two effects, the way the unit routes the signals through the effects is controlled by the program structure. There are two possible program structures: parallel (/) and serial (+).

Parallel (/) program

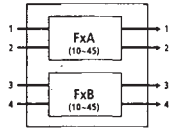

FxA and FxB are completely independent.

Serial (+) program



The sound from FxA is fed into FxB for further processing before being output.

If a 4ch effect is selected, the program contains only one effect (the other effect is automatically disabled).

Example of program containing a 4ch effect

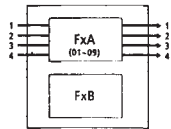

FxA only

Hooking Up

- Before connecting this unit to another device, be sure to unplug the AC power cord from the power outlet.
- Turn off the power switch on this unit and all components to be connected, such as keyboards and active speakers (speakers with built in amplifiers).
- After all the connections, double check that the connections are correct before plugging the AC power cord back into the power outlet.
- If the connected components output large signals that cause distortion, adjust the INPUT LEVEL knobs on this unit to lower the input level, or lower the output level of the connected component.

Example 1: Hooking up to instruments

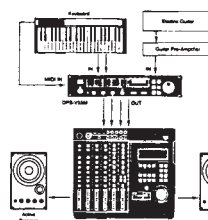

Example 2: Hooking up a mixer (Mono send, Stereo return)

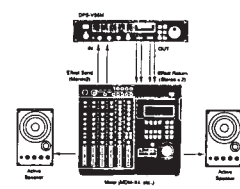

Example 3: Hooking up to a mixer (cutting the direct sound) (Stereo send, Stereo Return)

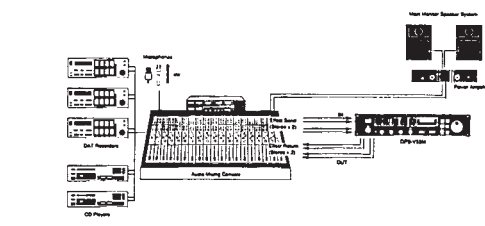

When using the processor in a send-return loop

- When using effect that have an effect level parameter, we recommend setting the direct sound to "0" so that only the sound of the effect will be output.
- We also recommend setting the BYPASS function to "Muting" (as shown on page 18).

8th

9th

Basic Operations

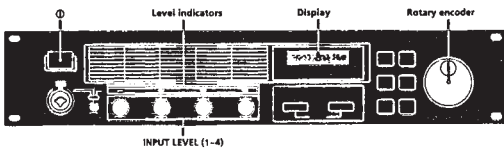

INPUT LEVEL (1-4)

Choosing a Program

The processor comes with 200 different preset programs (numbers 001-200) as well as room for 200 user programs for storing the programs you create (numbers 201-400). Use the following procedure to choose the program you desire.

- 1 Press **⏻** to turn on the power. After a few seconds, the play mode screen appears.

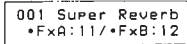

- 2 Turn INPUT LEVEL (1-4) to adjust the input levels.

If an input level indicator lights red (clip), the input level for that channel is set too high. Be sure to set the input level correctly since it has a direct relationship to the quality of the effects (see page 6 for details).



- 3 Turn the rotary encoder to select a program (001-400).

The program numbers (and corresponding names) appear in the display as you turn the jog dial.



Before you turn on the connected components Be sure to turn the volume level down to avoid an unexpected output of massive volume.

You can also search programs by effect type See page 12 for details.

Reading the Display

During play mode the display provides various information about the selected program

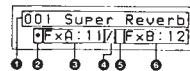

- 1 Program number and name: The number (001-400) and name of the current program.
- 2 FxA On/Off symbol: "+" : FxA is on (in the illustration, FxA is on). (Blank) : FxA is off
- 3 FxA effect number: The number (01-45) of the effect assigned to the current program's FxA block. The effect numbers correspond to those printed on the front panel to the left of the display. When a 4ch effect is assigned to the FxA block, the FxB effect number and the structure symbol do not appear in the display.
- 4 Structure symbol: "/" (Parallel) : To use FxA and FxB separately (the illustration shows a parallel structure). "+" (Serial) : To feed the output of FxA into FxB for additional processing. The structure symbols correspond to those printed on the front panel below the display. (See page 8 for details.)
- 5 FxB On/Off symbol: "+" : FxB is on (Blank) : FxB is off (in the illustration, FxB is off).
- 6 FxB effect number: The number (01-45) of the effect assigned to the current program's FxB block. The effect numbers correspond to those printed on the front panel to the left of the display.

Outputting Without Effects (BYPASS)

The bypass function allows you to output the original signal without adding any effects. This function can also be set to completely cut (mute) the sound output from the processor (see page 18 if you want to switch to muting).

Press **BYPASS** to activate the bypass (mute) function.

"BYPASS" (or "MUTING") appears in the display.



Press again to cancel and output with effects.

10th

11th

Basic Operations

Selecting Programs by Effect Block

This function lets you search for programs based on the type of effects they contain. In addition to being a good way to explore different implementations of the same effect, it is also a quick way locate a specific program.

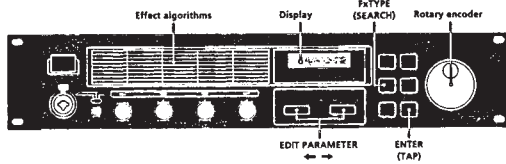

- 1 Press Fx TYPE (SEARCH) twice to display the search screen.

```
Search:01 Plat1
09B Super Reverb
```

- 2 Turn the rotary encoder to select an effect (01-45).
The numbers (01-45) and names of the effects correspond to those printed on the front panel to the left of the display.

```
Search:03 Room1
017 Sound Fx
```

The number and name of the first program containing the selected effect appear on the bottom line of the display.
You can also monitor the sound of this program.

- 3 Press EDIT PARAMETER → to move the cursor to the bottom line of the display.

```
Search:03 Room1
017 Sound Fx
```

- 4 Turn the rotary encoder to select a program.
Only programs containing the selected effect (displayed on the first line) will appear. You can also monitor the sound of these programs.

```
Search:03 Room1
147 Other Program
```

- 5 Press ENTER (TAP) to switch to the selected program.

"Executing" appears momentarily and the unit switches to the selected program (and back to play mode).

```
147 Other Program
• FxA:03
```

12

Editing a Program

Choosing the Effects

Use the following operations to choose the effect(s) to be used in your program. You can choose up to two effect blocks (when using 2ch [10-36] or Mono-Pair [37-45] effects). When using a 4ch effect (01-09), you may choose only one effect. (See page 8 for details).

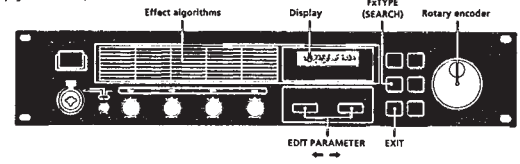

- 1 Press Fx TYPE (SEARCH) to display the type screen.

```
Fx TYPE:TYPE
• FxA:11 / • FxB:12
```

- 2 Turn the rotary encoder to select the effect (01-45) for FxA.

The numbers (01-45) correspond to the effects printed on the front panel to the left of the display.

```
Fx TYPE:TYPE
• FxA:45 / • FxB:12
```

When you select a 4ch effect (numbers 01-09), press EXIT to return to play mode and skip the following steps.

- 3 Press EDIT PARAMETER → twice to move the cursor to FxB.

Note: this is not possible if you select a 4ch effect (01-09) in the previous step.

```
Fx TYPE:TYPE
• FxA:45 / • FxB:12
```

- 4 Turn the rotary encoder to select an effect (10-45) for FxB.

The numbers (10-45) correspond to the effects printed on the front panel.

```
Fx TYPE:TYPE
• FxA:45 / • FxB:30
```

- 5 Press EXIT to return to play mode.

To change the structure type before returning to the play mode, press EDIT PARAMETER → to switch to the structure parameter, then proceed from step 3 of "Choosing the Structure".

13

Editing a Program

Choosing the Structure

This function lets you choose the structure of the effect blocks. Note, this setting is only possible when you have selected effects for both FxA and FxB. (It is not possible when using 4ch effects).

- 1 Press Fx TYPE to display the effect type screen.

```
Fx TYPE:TYPE
• FxA:11 / • FxB:12
```

- 2 Press EDIT PARAMETER → to display "Struct".

The structure symbol starts blinking.

```
Fx TYPE:Struct
• FxA:11 / • FxB:12
```

- 3 Turn the rotary encoder to select "/" or "•".

The structure symbols correspond to those printed on the front panel below the display.

/ : Parallel

Allows you to use FxA and FxB separately.

With this structure, channels 1 and 2 are processed separately from channels 3 and 4.

• : Serial

Allows you to feed the output of FxA into FxB for additional processing.

With this structure, channel 1 is mixed with channel 3 and channel 2 is mixed with channel 4.

- 4 Press EXIT to return to play mode.

Changing the Parameters

Use the following procedures to:

- Turn an effect on or off.
- Adjust individual effect parameters (FxA or FxB)
- Adjust the master volume (output) of the program.

For descriptions of the parameters available for each effect, refer to the separate Effect Parameter Guide.

- 1 Press EDIT PARAMETER ← or → repeatedly to display the parameter you want to adjust.

- 2 Turn the rotary encoder to change the parameter.

- 3 Repeat steps 1 and 2 to change all necessary parameters.

Press EDIT PARAMETER ← and → at the same time to skip to the next parameter group instead of switching parameters one at a time.

The name of the parameter group is shown at the top of the display. The individual parameters and parameter values appear at the bottom.

Parameter group	
Parameter	Setting
Edit:Fx On/Off	[On]
FxA On/Off	[On/Off]

Parameter group	contains parameters that
Fx On/Off	Turn FxA and FxB ^{**} off or on.
FxA [effect name ^{**}]	Change the sound produced by FxA. The number and type of parameters available depends on the effect block. ^{**}
FxB ^{**} [effect name ^{**}]	Change the sound produced by FxB. The number and type of parameters available depends on the effect block. ^{**}
Master Level	This parameter lets you adjust the output level of the current program.

^{**} There are no FxB parameters when FxA is a 4ch effect.

^{**} The effect name is abbreviated to 5 characters.

^{**} Refer to the separate Effect Parameter Guide for detailed information.

- 4 Press EXIT to return to play mode.

14

Using the TAP function

This function lets you change the value of certain time related parameters or trigger an effect by tapping on the ENTER (TAP) button.

The parameter which responds to the TAP function is different for each effect, and not all effects have compatible parameters. However, many time related parameters (such as Delay Time) or parameters activated by a trigger (such as Key Trigger) are designed to work with the TAP function. (Refer to the separate Effect Parameter Guide for specific information.)

The TAP function works the same in either play mode or edit mode, but not can not be used when any other modes (such as SYSTEM or SAVE) are active.

To use TAP with time related parameters ("Time" below)

Select a program containing a compatible effect, then tap ENTER (TAP) repeatedly to enter the desired tempo. The effector's tap editor measures the timing of the last two taps and sets the corresponding parameter accordingly. You can also change the ratio between your taps and the actual parameter value (see page 18 for details).

To use TAP as a trigger ("Trigger" below)

Press ENTER (TAP) at the point where you want to activate the effect.

Effects that can be adjusted using the TAP function.

Number	Name	TAP type
7	Rotary Speaker	Trigger
9	Doppler	Trigger
15	Stereo Delay	Time
16	Ping Pong Delay	Time
22	Stereo Panner	Trigger
23	Haas Panner	Trigger
31	Tremolo	Trigger
32	Vibrato	Trigger
34	Flitch Roller	Trigger
36	Freeze	Trigger

You can also use MIDI to control the TAP function. Data above 40H received on Control Change 04H produces the same effect as pressing ENTER (TAP) on the front panel.

15

Editing a Program

Saving your Program

New programs created by changing effect blocks, effect structures, and effect parameters can be stored in memory for later use. You can store up to 200 different user programs using program numbers 201-400.

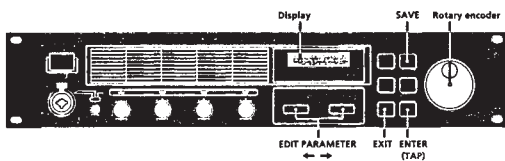

1 Press SAVE to activate the save mode.

The program number starts blinking. (A previously saved program name appears in the display.)

Save:
201 Super Reverb

2 Turn the rotary encoder to select the program number (201-400) where you want to save the effect.

(A previously saved program name appears in the display.)

Save:
300 StereoChorus

3 Press EDIT PARAMETER to move the cursor to the program name.

The name of the program you edited appears in the display and the first character starts to blink.

Save:
300 Super Delay

4 Turn the rotary encoder to select a character.

Save:
300 Super Delay

5 Use EDIT PARAMETER to move the cursor into place for the next character.

Repeat steps 4 and 5 to enter up to 12 characters.

6 When you've finished entering the characters, press SAVE (or ENTER (TAP)).

Save:OK?
N[EXIT]/Y[ENTER]

7 The unit will ask for confirmation before saving the program.

To execute the save operation, press ENTER (TAP). If you press ENTER (TAP), "Writing..." appears momentarily, the program is saved, and the unit switches back to the play mode. If you do not want to save the program, press EXIT. If you press EXIT, the unit returns directly to the play mode without saving the program.

300 X My Program
*FxA:24/*FxB:31

System Operations

The system settings allow you to customize this unit's operating environment. You can specify how the unit will respond to MIDI commands and how the BYPASS and TAP functions will operate.

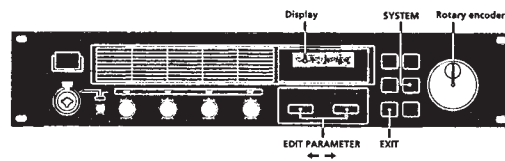

MIDI Settings

You can use the MIDI interface to control various aspects of this unit. For example, you can switch between memorized effects by using the program table, or save your custom effects to an external storage device.

1 Press SYSTEM.

The first MIDI parameter (MIDI channel) appears automatically.

2 Press EDIT PARAMETER to choose the MIDI parameter you want to adjust.

The "MIDI Ch" parameter lets you specify the MIDI channel (1-16).

System:MIDI Ch
Channel 01

The "MIDI Omni" parameter lets you turn the omni function on or off.

System:MIDI Omni
Omni Mode On

The "MIDI Out" parameter lets you specify the function of the MIDI OUT/THRU jack.

System:MIDI Out
Out/Thru Thru

The "MIDI Tabl" parameter lets you create a MIDI program table that specifies which MIDI program change commands will activate which programs.

System:MIDI Tabl
MIDI#001-Prs#001

The "MIDI Bulk" parameter lets you specify the range of MIDI data to be output.

System:MIDI Bulk
Trans Sys-#400

3 Use the rotary encoder to make the adjustments you desire.

Setting the MIDI channel

- 1 Use the rotary encoder to specify the MIDI channel (1-16).
- 2 Press EXIT to return to the play mode or press EDIT PARAMETER to switch to another parameter.

Setting the MIDI omni operation

- 1 Use the rotary encoder to select "On" or "Off".
- 2 Press EXIT to return to the play mode or press EDIT PARAMETER to switch to another parameter.

Setting the MIDI Thru/Out

- 1 Use the rotary encoder to select "Thru" or "Out".
Thru: Data input to the MIDI IN jack is output as is.
Out: Outputs bulk transfer data, etc.
- 2 Press EXIT to return to the play mode or press EDIT PARAMETER to switch to another parameter.

16

17

System Operations

Setting the MIDI Program Table

- 1 Use the rotary encoder to specify the MIDI program change number.

System:MIDI Tabl
MIDI#001-Prs#001

2 Press EDIT PARAMETER.

- 3 Use the rotary encoder to specify the program to be switched to.

System:MIDI Tabl
MIDI#006-Prs#006

- 4 Press EXIT to return to the play mode or press EDIT PARAMETER to switch to another parameter.

Setting the MIDI Bulk Transfer Options

- 1 Make sure the "MIDI Thru/Out" setting is set to "Out".
- 2 Use the rotary encoder to select "Sys" or the first program number to be transferred.

You can transfer either system settings or program data. (Sys): Transfers data for the settings made in the system mode (#201-#400). Transfers the program data for the specified range of program numbers.

System:MIDI Bulk
Trans #201-#400

3 Press EDIT PARAMETER.

- 4 Use the rotary encoder to select the last program number to be transferred.

System:MIDI Bulk
Trans Sys-#400

5 Press ENTER (TAP) to output the data.

"Transferring..." appears during the transfer. When finished, the "MIDI Bulk" parameter reappears.

- 6 Press EXIT to return to the play mode or press EDIT PARAMETER to switch to another parameter.

Other Settings

The system set up parameters let you to select how the BYPASS button and TAP function parameters will operate. For example, you can set BYPASS mute the output of the processor instead of passing the input signal.

1 Press SYSTEM twice.

The first set up parameter ("Bypass") appears automatically.

System:Set Up
BYP Mode Bypass

2 Use the rotary encoder to select "Bypass" or "Muting".

Select	When
Bypass	you want to output the original signal without adding any effects. Only the original signal is output (see "Bypass" on page 11).
Muting	you want to completely cut the sound output from the processor (including the input signal). We especially recommend using mute when connecting the processor in a send-return loop with a mixer (as shown on page 9).

3 Press EDIT PARAMETER to switch to "Tap".

System:Set Up
Tap Mode x1

4 Use the rotary encoder to select "x1/4", "x1/3", "x1/2", "x1", "x2", or "x3".

These represent different ratios for calculating the values input via the TAP function. Example: When the tap is set to "x1/4", tapping at a rate that would normally create a 1 second delay creates a 0.25 second delay.

5 Press EXIT to return to the play mode.

Sony Multi Effect Processor DPS-V55M MIDI Implementation Chart

Mar 01, 1998 Version: 1.0

Function...	Transmitted	Recognized	Remarks
Basic Channel	Default Changed X X	1-16 1-16	Memorized
Mode	Default Messages Altered X X *****	OMNI ON/OFF X X	Memorized
Note Number	True Voice X *****	X X	
Velocity	Note ON Note OFF X X	X X	
After Touch	Key's Ch's X X	X X	
Pitch Bend	X	X	
Control Change	0 - 31, 64 - 120 X	O	07H (Main Volume) 04H only
Prog Change	True# X *****	O 0-127	*1
System Exclusive	O	O	
Common	: Song Pos : Song Sel : Tune X X X	X X X	
System Real Time	: Clock : Commands X X	X X	
Aux Messages	: Local ON/OFF : All Notes OFF : Active Sense : Reset X X X X	X X X X	
Notes	*1: It can be received on the play mode only.		

Mode 1: OMNI ON, POLY Mode 2: OMNI ON, MONO O: YES
Mode 3: OMNI OFF, POLY Mode 4: OMNI OFF, MONO X: NO

18

SECTION 3 DISASSEMBLY

Note: Follow the disassembly procedure in the numerical order given.

CASE

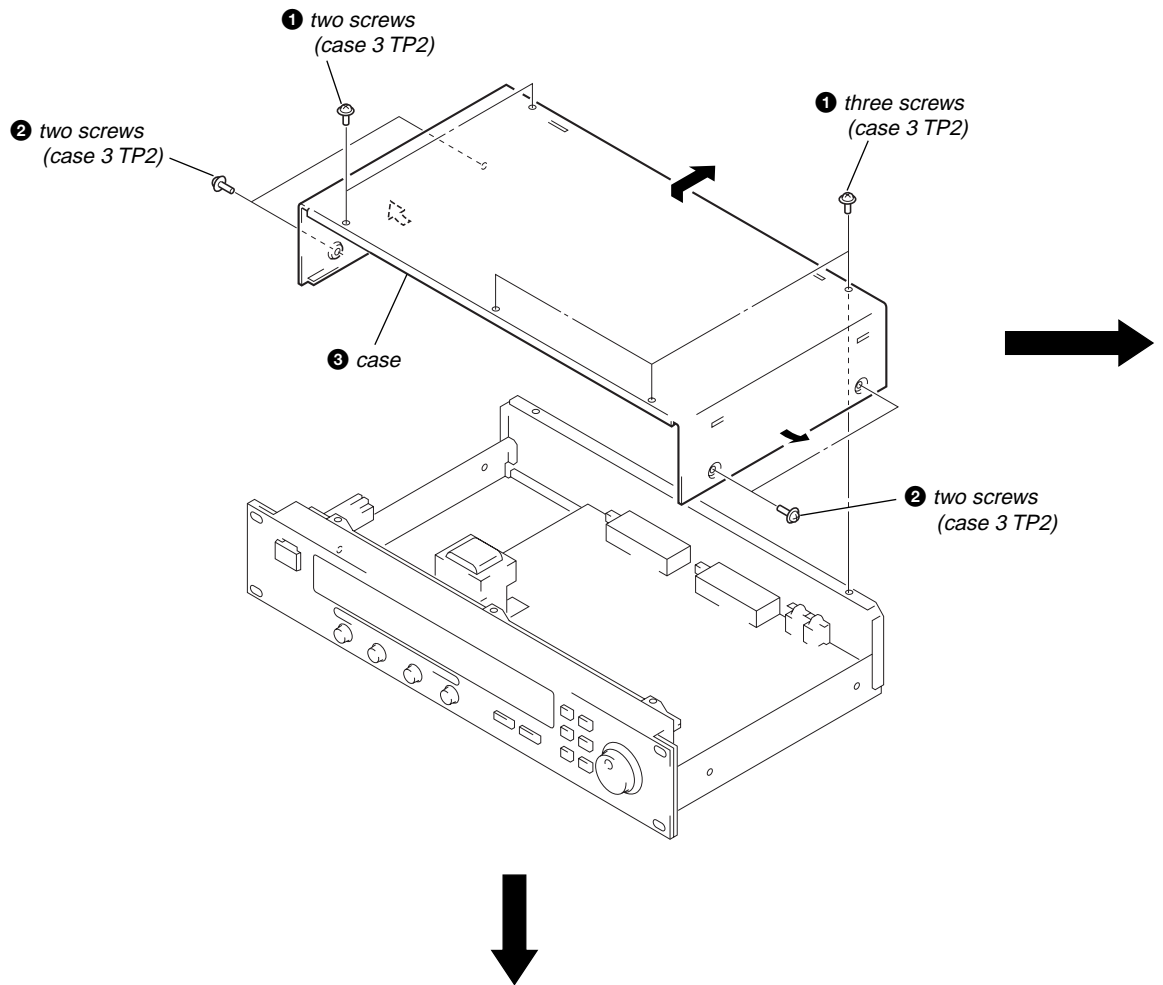

FRONT PANEL ASS'Y

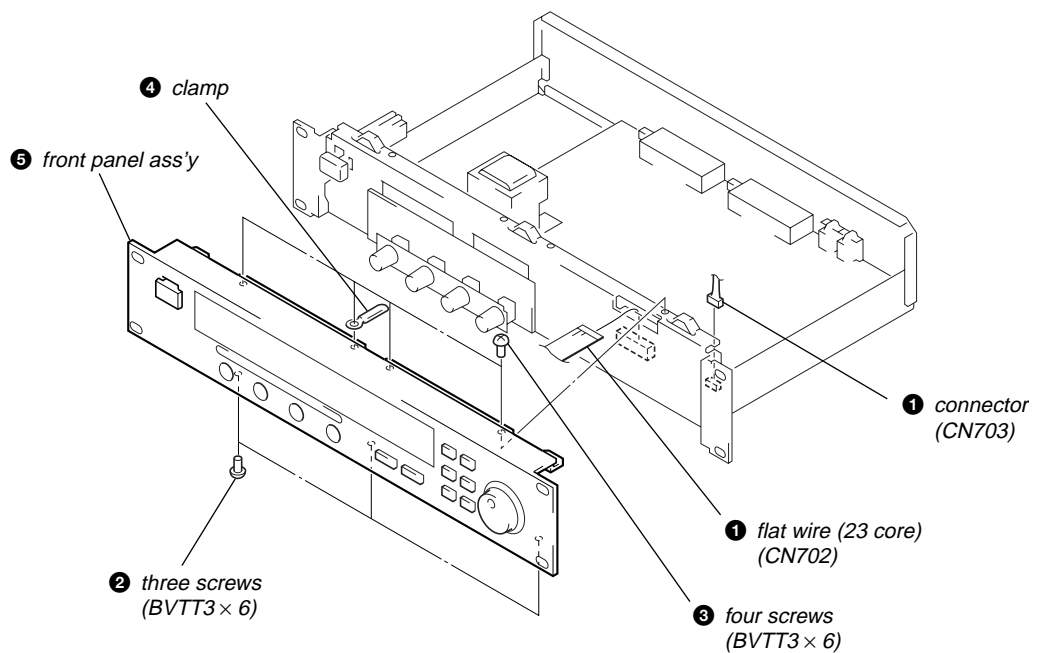

BACK PANEL

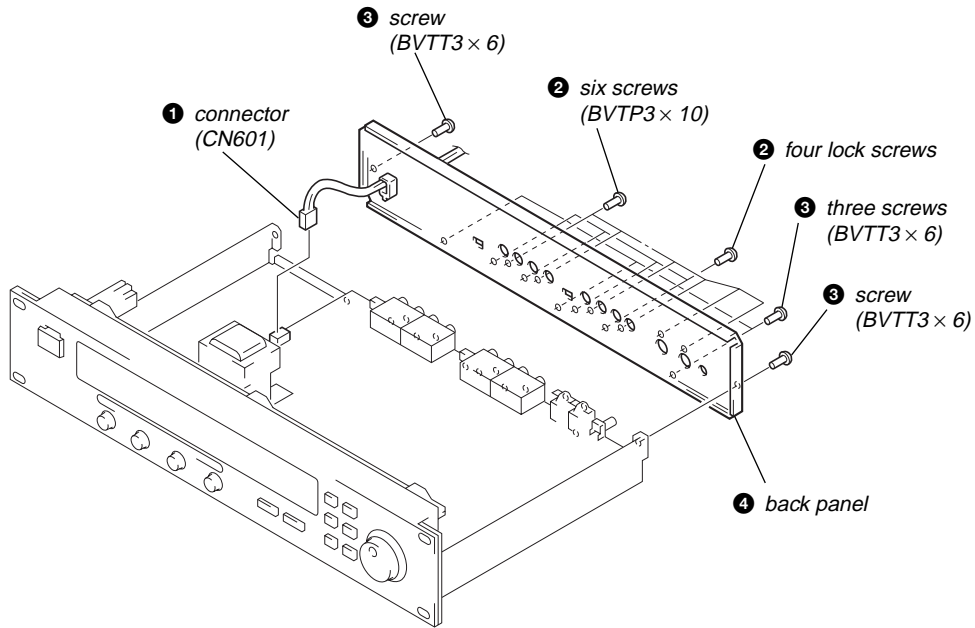

MAIN BOARD

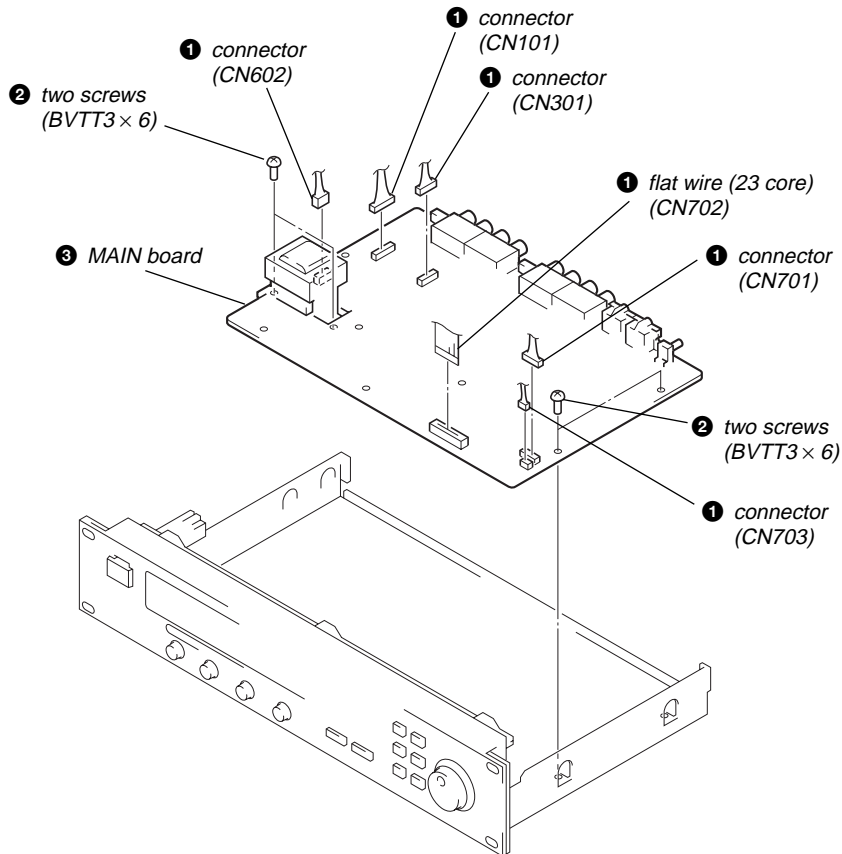

SECTION 4 TEST MODE

[Operation of Test Mode]

- The test mode is executed according to order the following.
- Press button, and come back the before item.

1 Begin the test mode

- 1) Press button while Press three buttons , and simultaneously.
- 2) The self-diagnosis is executed and indicated error messages in case of something wrong a hardware (See [Self-diagnosis Message]), begin the test mode in case of no damage.

Display:

T e s t M o d e !
* * * * *

2 Key switch and rotary encoder check

- 1) Press any switch button, and display a figure to button.

Button	Display	Button	Display
→	0	ENTER	4
←	1	SAVE	5
BYPASS	2	SYSTEM	6
Fx TYPE	3	EXIT	7

- 2) Right down of display value increases like 1, 2, 3..... if rotating JOG knob in clockwise, or decreases like 0, 9, 8..... if rotating in counter clockwise.
(Limit of figure: 000 to 255)

Display:

T e s t M o d e !
0 1 2 3 4 5 6 7 * * * * * 0 2 6

*switch button's figure
(state of pressed all)*
*rotary encoder count
(optional value)*

3 MIDI circuit check

- Preparation:
The MIDI cable (DIN cable) between MIDI IN connector and MIDI OUT/THRU connector.
(If not available this check with not connect cable)
- 1) Press button.
(This check begin with display all figure of switch button and rotary encoder position.)
 - 2) Begin the MIDI circuit check, and display result.
- Display: No problem

M I D I C h e c k I n O u t
G o o d !

Circuit problem or no connecting cable

M I D I C h e c k I n O u t
N G !

- If retry of check, Press button, and Press button with begin.

4 Signal check 1 (Bypass check mode)

- 1) Press button.
- 2) Enter the bypass check mode.
Analog output muting is OFF, and each channel the output signal as intact as input signal.

Display:

S i g n a l C h e c k 1
< B y p a s s M o d e >

5 Signal check 2 (Sine wave output mode)

- 1) Press button.
- 2) Enter the sine wave output mode.
Each channel output jack output a sine wave 1 kHz (about 7.3 Vp-p). (Input have muting)

Display:

S i g n a l C h e c k 2
< A u t o S i n M o d e >

6 Ending the test mode

- 1) Press button.
- 2) The display change the following.

Display:

A l l I n i t i a l i z e ?
N = E x i t , Y e s = E n t e r

- Item ① or ② is executed at the work contents.
- ① Next item (A) - (E) is press button.
 - (A) Change the ROM.
 - (B) Change the battery.
 - (C) Change the RAM.
 - (D) Customer request is initial state.
 - (E) Besides the above-mentioned. Repair connected with hardware on the main board.

This case display the following few seconds, and come up power. (Initialize is done.)

Display:

A l l I n i t i a l i z e ! !

- ② Next item (F), (G) is press button.
 - (F) Hardware is not change repair.
 - (G) Only check, such as function check.

This case come up power usual. (No initialize)

[Self-diagnosis Display]

(1) ROM Error

Contents: Data of EPROM (IC704) is wrong.

Method:

- Check the bridge is possible and if find out a repair.
- IC704 insert the socket is wrong, if find out a insert again.

Display:

R O M E r r o r !

(2) Internal RAM Error

Contents: Internal RAM of micro computer (IC701) is wrong.

Method:

- Perform an initialize. (See Initialize Method.)
- Replace the IC701, if do not restore of the initialize is not happen another error messages.

Display:

I n t . R A M E r r o r !

(3) External RAM Error

Contents: Internal data of SRAM (IC702) is wrong.

Method:

- Check the bridge is possible and if find out a repair.
- Perform an initialize. (See Initialize Method.)
- Replace the IC702, if do not restore of these items the above-mentioned and not happen another error messages.

Display:

E x t . R A M E r r o r !

(4) DRAM Error

Contents: Internal data of DRAM (IC503) is wrong.

Method:

- Check the bridge is possible and if find out a repair.

Display:

D R A M E r r o r !

(5) Battery Low

Contents: Exhaust the power of lithium battery (BA501).

Method:

- Replace the BA501.
- Check a point of contact, if do not restore of replace the BA501.

Display:

B a t t e r y L o w !

[Initialize Method]

Press three buttons **[SAVE]**, **[SYSTEM]**, and **[POWER]** simultaneously, and the display of fluorescent indicator tube changes to "All Initialize!!", and restart system.

A l l I n i t i a l i z e ! !

SECTION 5 DIAGRAMS

• Circuit Boards Location

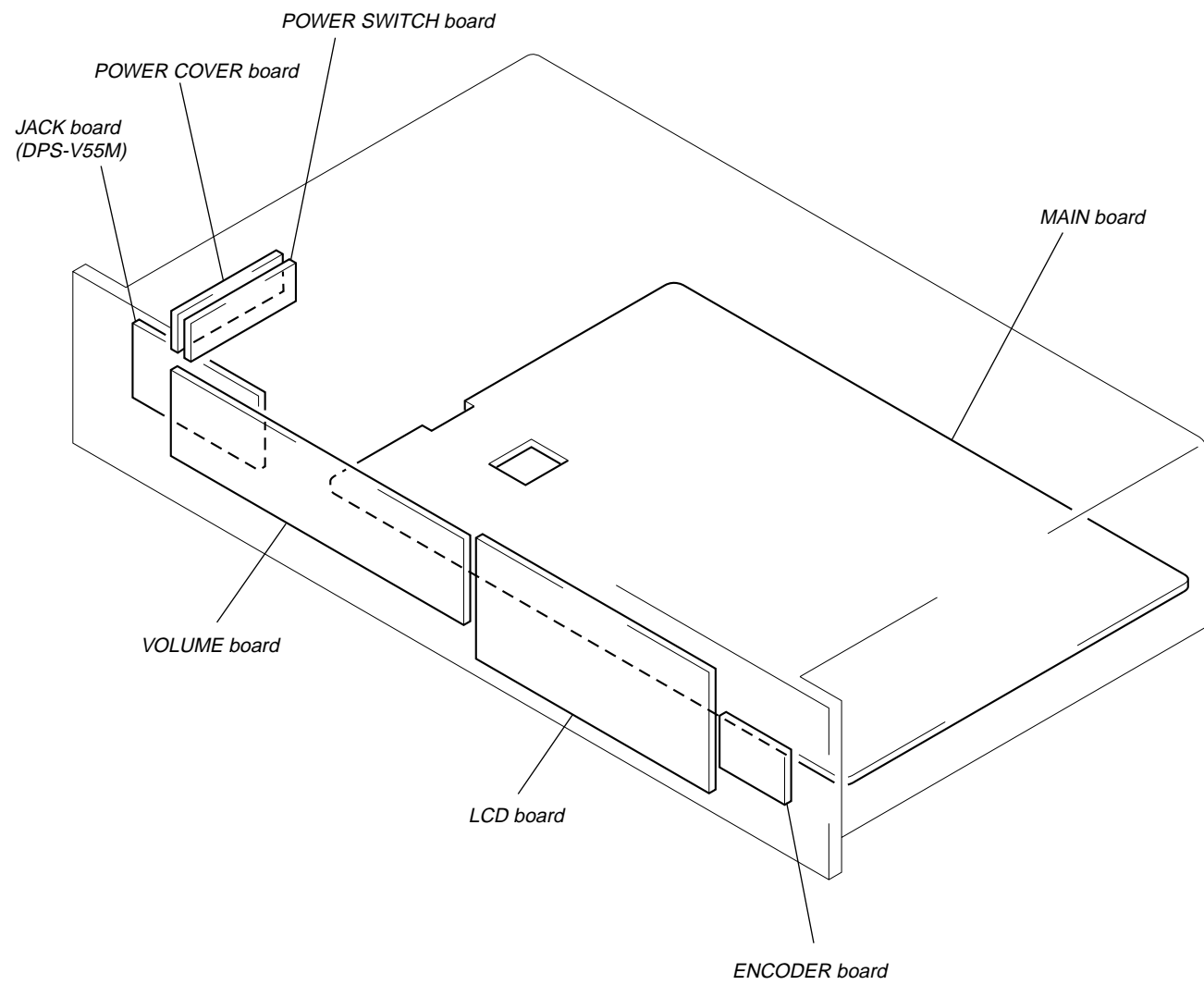

THIS NOTE IS COMMON FOR PRINTED WIRING BOARDS AND SCHEMATIC DIAGRAMS.
(In addition to this, the necessary note is each block.)

Note on Schematic Diagram:

- All capacitors are in μF unless otherwise noted. pF : $\mu\mu\text{F}$
50 WV or less are not indicated except for electrolytics and tantalums.
- All resistors are in Ω and $1/4\text{W}$ or less unless otherwise specified.
- : panel designation.

Note:

The components identified by mark Δ or dotted line with mark Δ are critical for safety.
Replace only with part number specified.

Note:

Les composants identifiés par une marque Δ sont critiques pour la sécurité.
Ne les remplacer que par une pièce portant le numéro spécifié.

• Signal path.

- : CH1
- : CH2
- : CH3
- : CH4
- : DIGITAL (CH1, 2)
- : DIGITAL (CH3, 4)

Note on Printed Wiring Boards:

- : parts extracted from the component side.
- : parts extracted from the conductor side.
- : Pattern from the side which enables seeing.
- Indication of transistor.

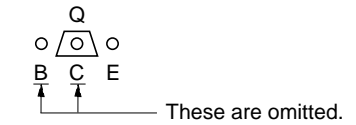

- B+ : B+ Line.
- B- : B- Line.
- Voltages and waveforms are dc with respect to ground under no-signal conditions.
- Voltages are taken with a VOM (Input impedance 10 M Ω). Voltage variations may be noted due to normal production tolerances.
- Waveforms are taken with a oscilloscope. Voltage variations may be noted due to normal production tolerances.
- Circled numbers refer to waveforms.

• IC Block Diagrams – MAIN BOARD –

IC501, 551 CS4222-KS

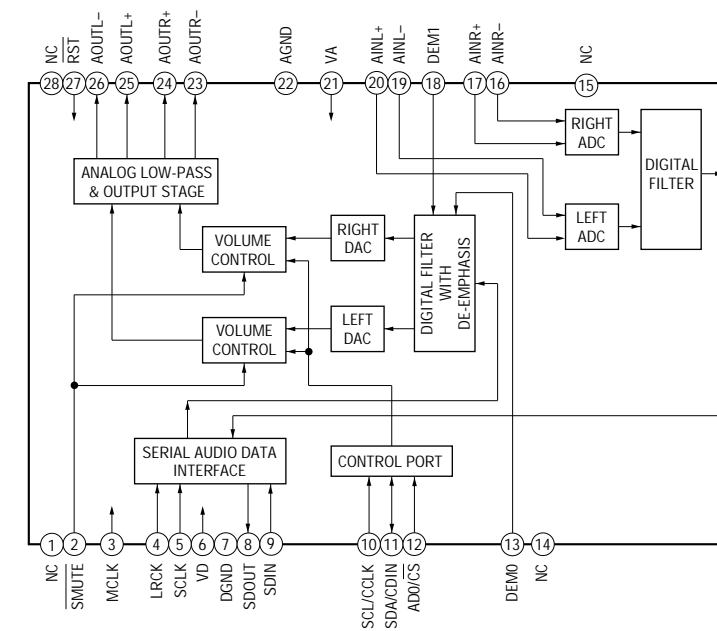

IC703 M62021FP-600C

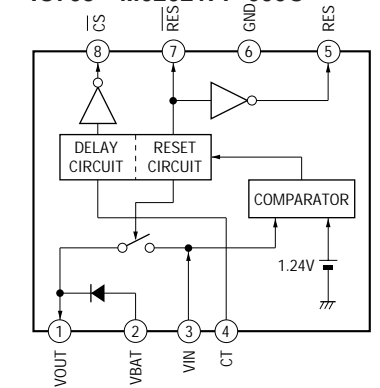

IC505 TC74VHC74F

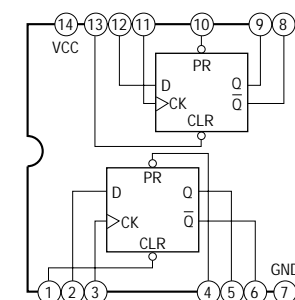

5-1. PRINTED WIRING BOARD – MAIN Section –

• See page 13 for Circuit Boards Location. • See page 14 for Note on Printed Wiring Board.

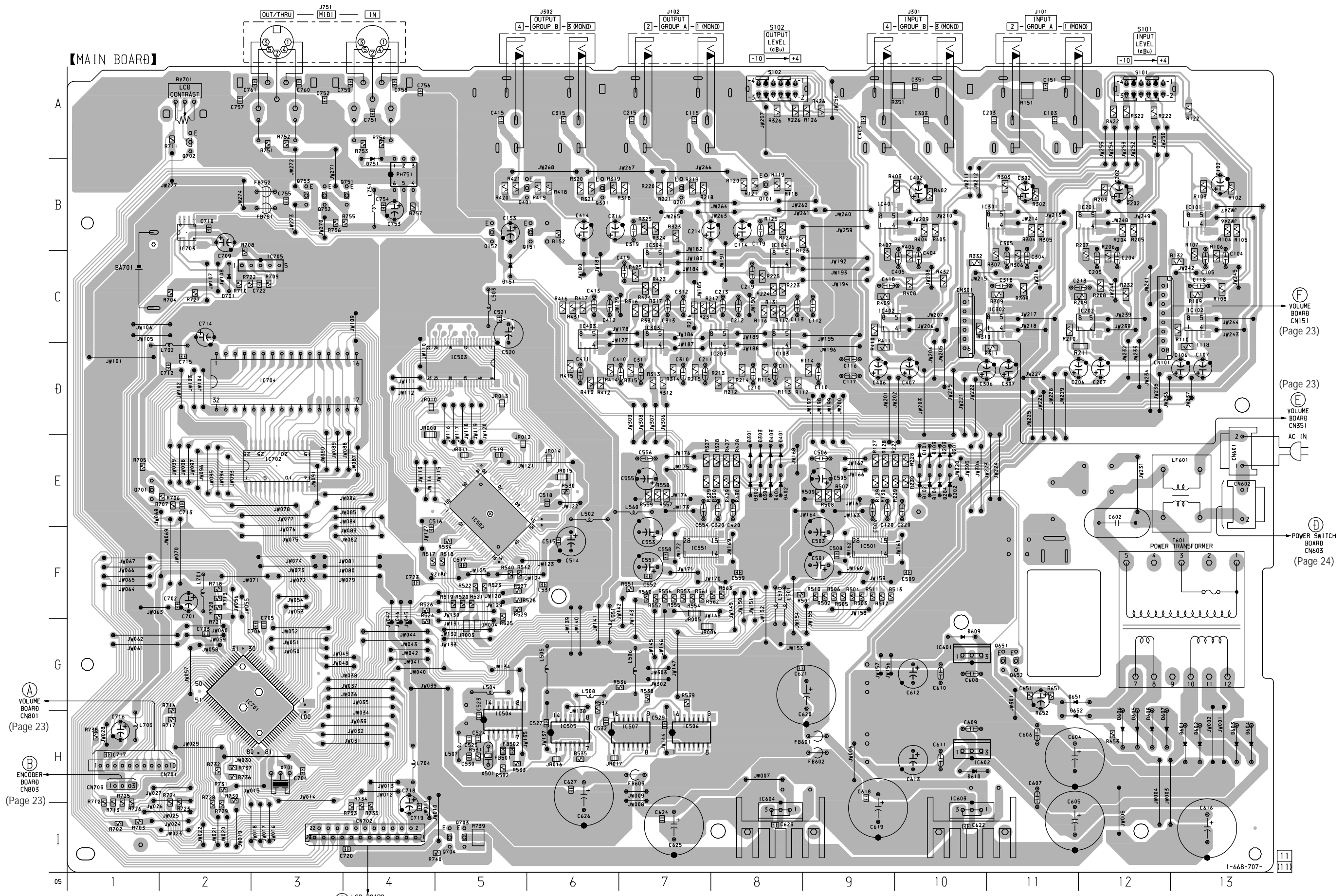

• Semiconductor Location

5-2. SCHEMATIC DIAGRAM – MAIN Section (1/3) –

• See page 14 for Note on Schematic Diagram and IC Block Diagrams. • See page 27 for Waveforms.

Ref. No.	Location
D101	E-10
D102	E-10
D103	E-10
D104	E-10
D151	C-5
D201	E-10
D202	E-10
D203	E-10
D204	E-10
D301	E-8
D302	E-8
D303	E-8
D304	E-8
D401	E-8
D402	E-8
D403	E-8
D404	E-8
D601	H-13
D602	H-13
D603	H-13
D604	H-13
D605	H-12
D606	H-12
D607	H-12
D608	H-12
D609	G-10
D610	H-10
D651	G-11
D652	H-11
D701	C-2
D751	B-4
IC101	B-13
IC102	C-13
IC103	C-8
IC104	C-8
IC201	B-12
IC202	C-12
IC203	C-8
IC301	B-11
IC302	C-11
IC303	C-7
IC304	C-7
IC401	B-9
IC402	C-9
IC403	C-6
IC501	F-9
IC502	E-5
IC503	D-5
IC504	H-5
IC505	H-6
IC506	H-7
IC507	H-7
IC551	F-7
IC601	G-10
IC602	H-10
IC603	I-10
IC604	I-8
IC701	G-3
IC702	E-3
IC703	B-2
IC704	D-3
IC705	C-3
Q101	B-8
Q151	B-6
Q152	B-5
Q201	B-7
Q301	B-6
Q401	B-6
Q651	G-11
Q652	G-11
Q701	E-1
Q702	A-2
Q703	I-5
Q704	I-5
Q751	B-4
Q752	B-3
Q753	B-3

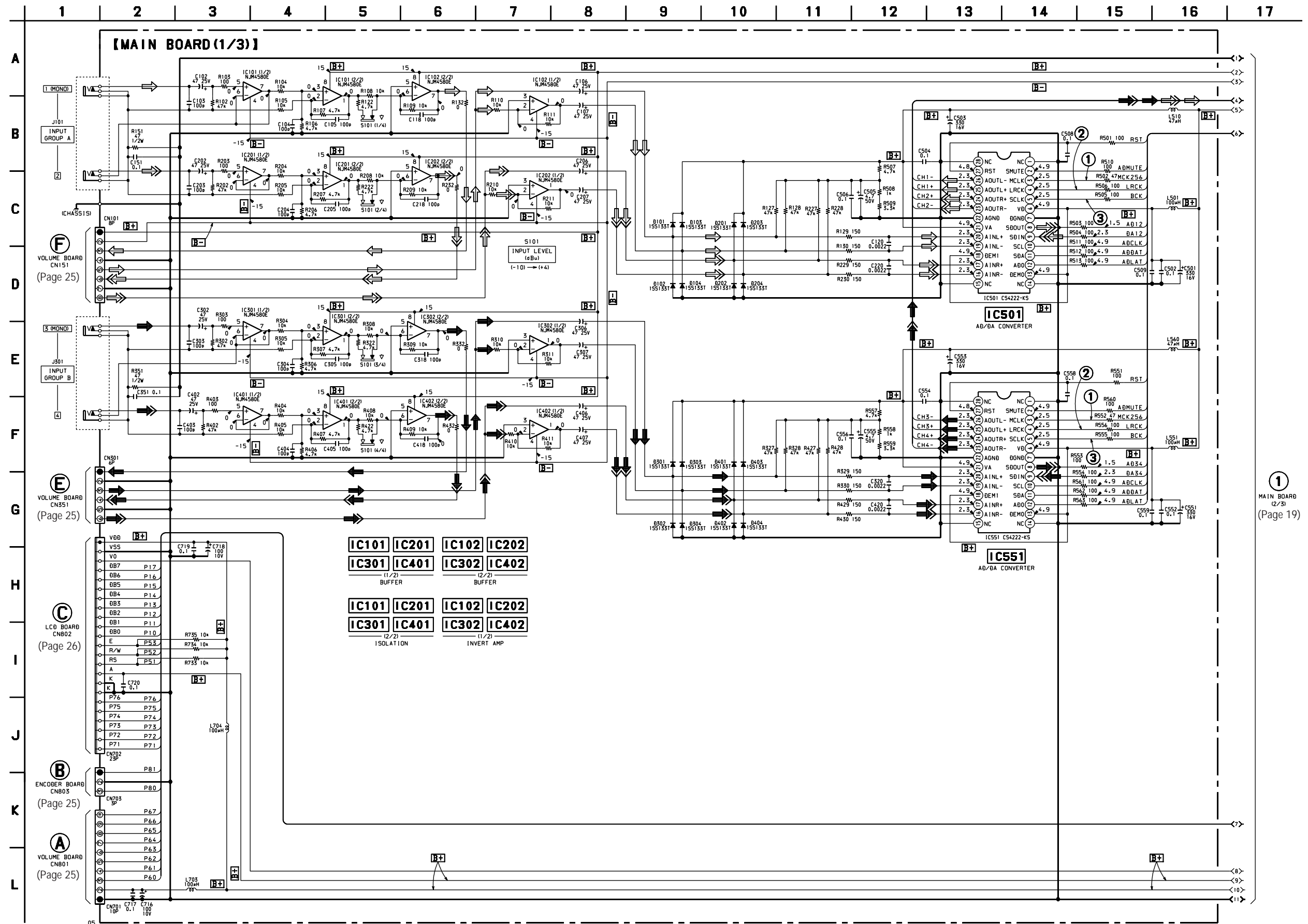

① MAIN BOARD (2/3) (Page 19)

5-3. SCHEMATIC DIAGRAM – MAIN Section (2/3) –

• See page 14 for Note on Schematic Diagram and IC Block Diagrams. • See pages 15 and 16 for Printed Wiring Board. • See page 27 for Waveforms.

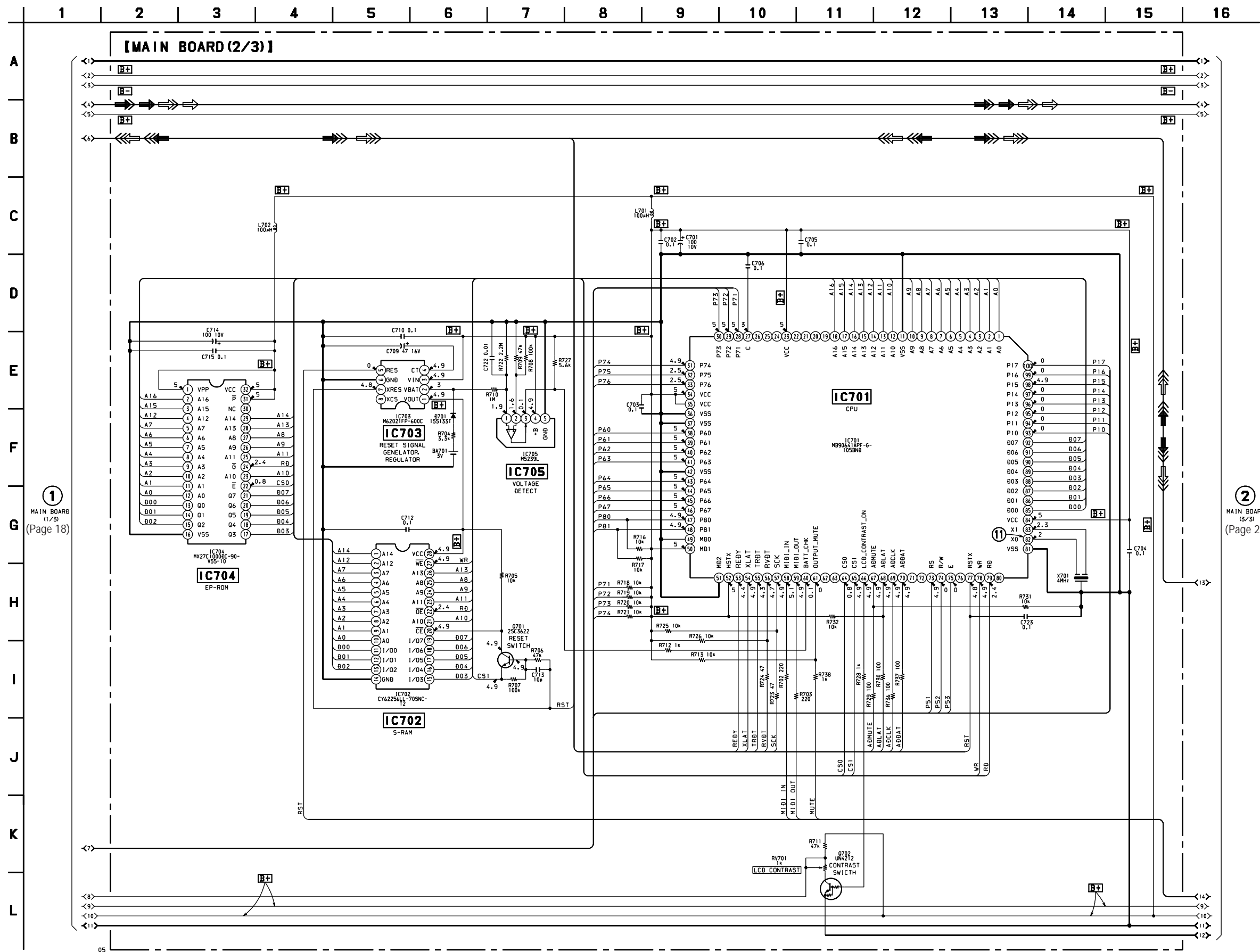

1 MAIN BOARD (1/3) (Page 18)

2 MAIN BOARD (3/3) (Page 21)

5-4. SCHEMATIC DIAGRAM – MAIN Section (3/3) –

• See page 14 for Note on Schematic Diagram and IC Block Diagrams. • See pages 15 and 16 for Printed Wiring Board. • See page 27 for Waveforms.

The components identified by mark Δ or dotted line with mark Δ are critical for safety. Replace only with part number specified.

Les composants identifiés par une marque Δ sont critiques pour la sécurité. Ne les remplacer que par une pièce portant le numéro spécifié.

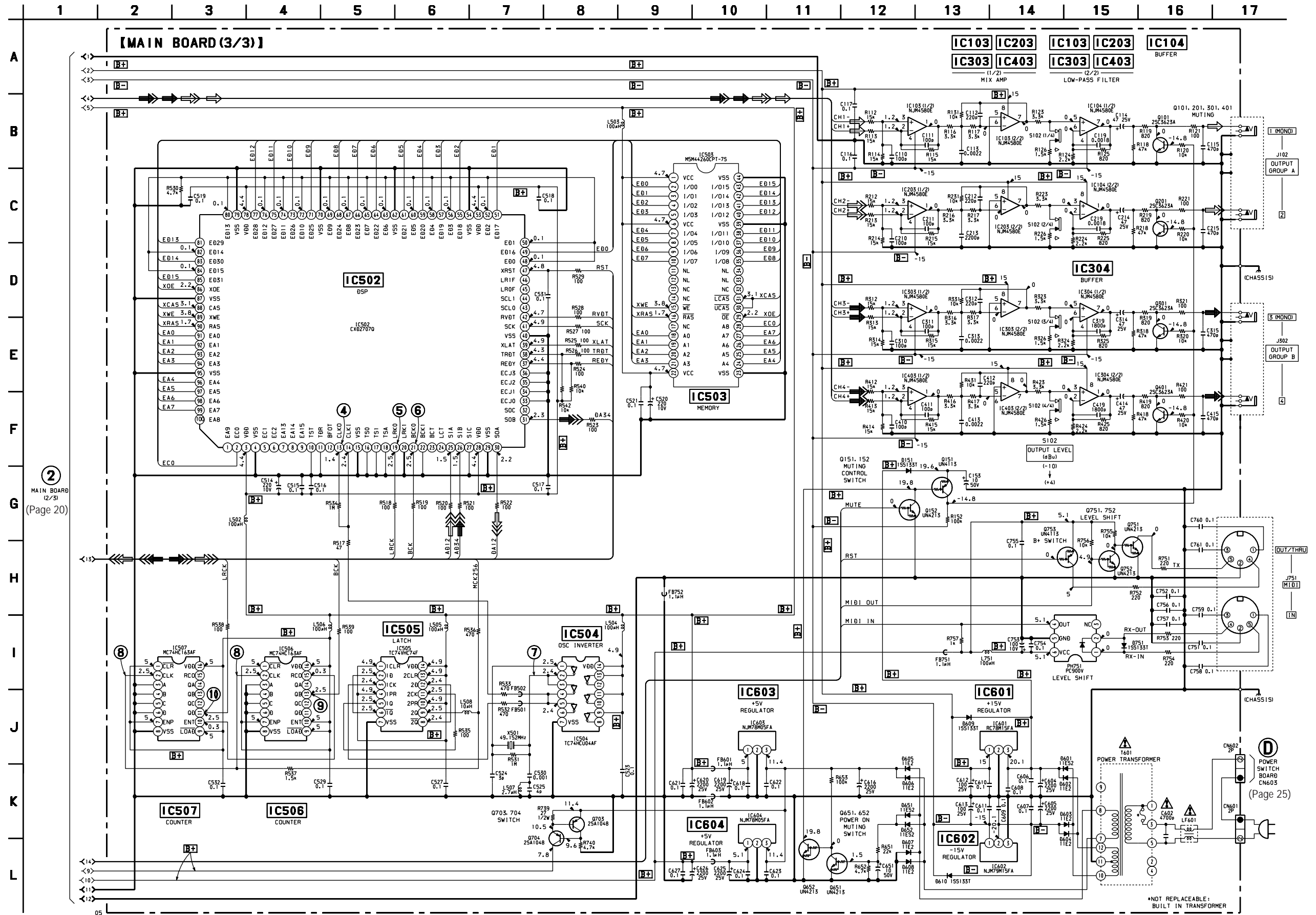

2 MAIN BOARD (2/3) (Page 20)

D POWER SWITCH BOARD CN603 (Page 25)

*NOT REPLACEABLE: BUILT IN TRANSFORMER

5-5. PRINTED WIRING BOARDS – PANEL Section –

• See page 13 for Circuit Boards Location. • See page 14 for Note on Printed Wiring Boards.

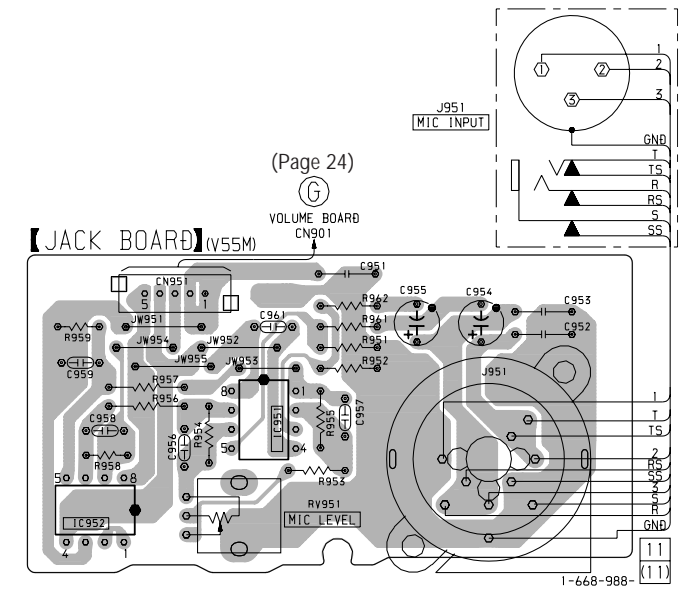
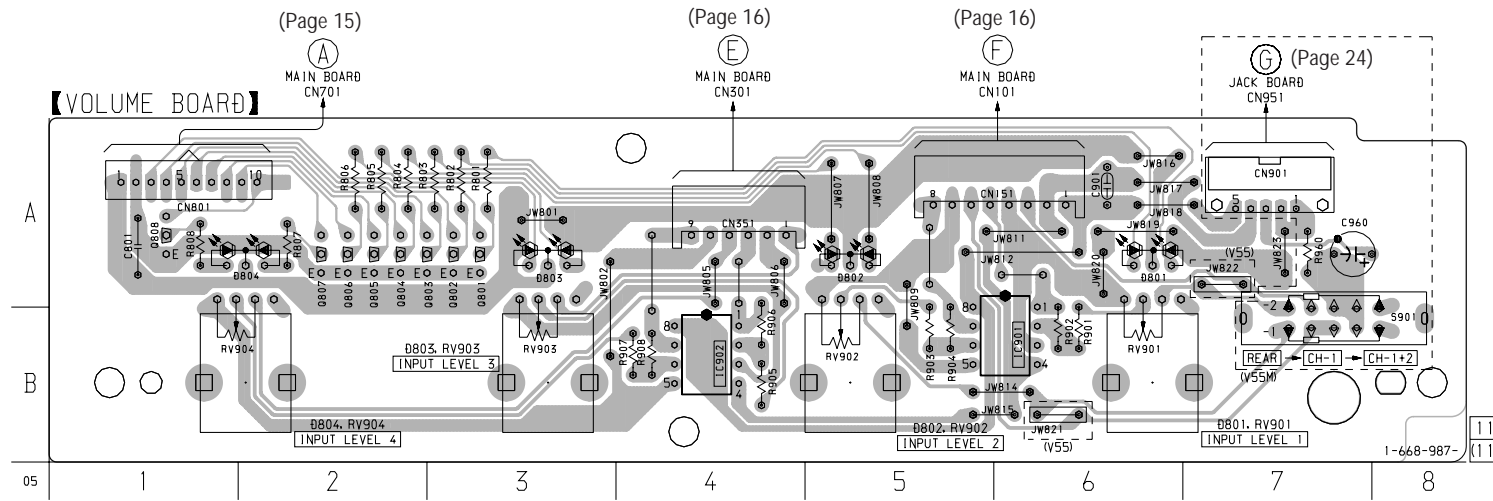
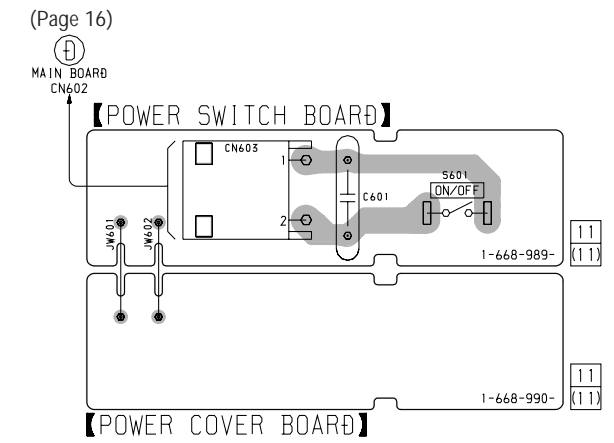
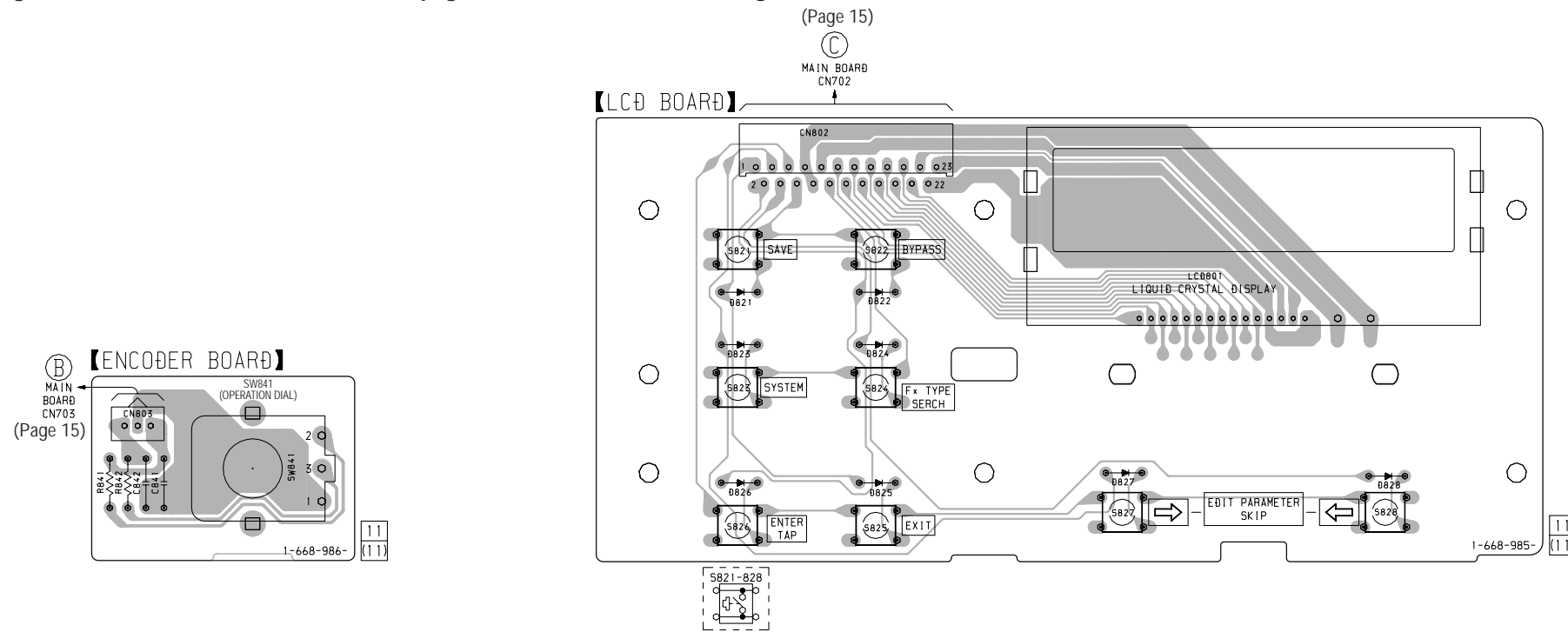

• Semiconductor Location – VOLUME BOARD –

Ref. No.	Location	Ref. No.	Location
D801	A-4	Q801	A-3
D802	A-5	Q802	A-3
D803	A-3	Q803	A-3
D804	A-2	Q804	A-2
		Q805	A-2
IC901	B-6	Q806	A-2
IC902	B-3	Q807	A-2
		Q808	A-1

5-6. SCHEMATIC DIAGRAM – PANEL Section –
 • See page 14 for Note on Schematic Diagram.

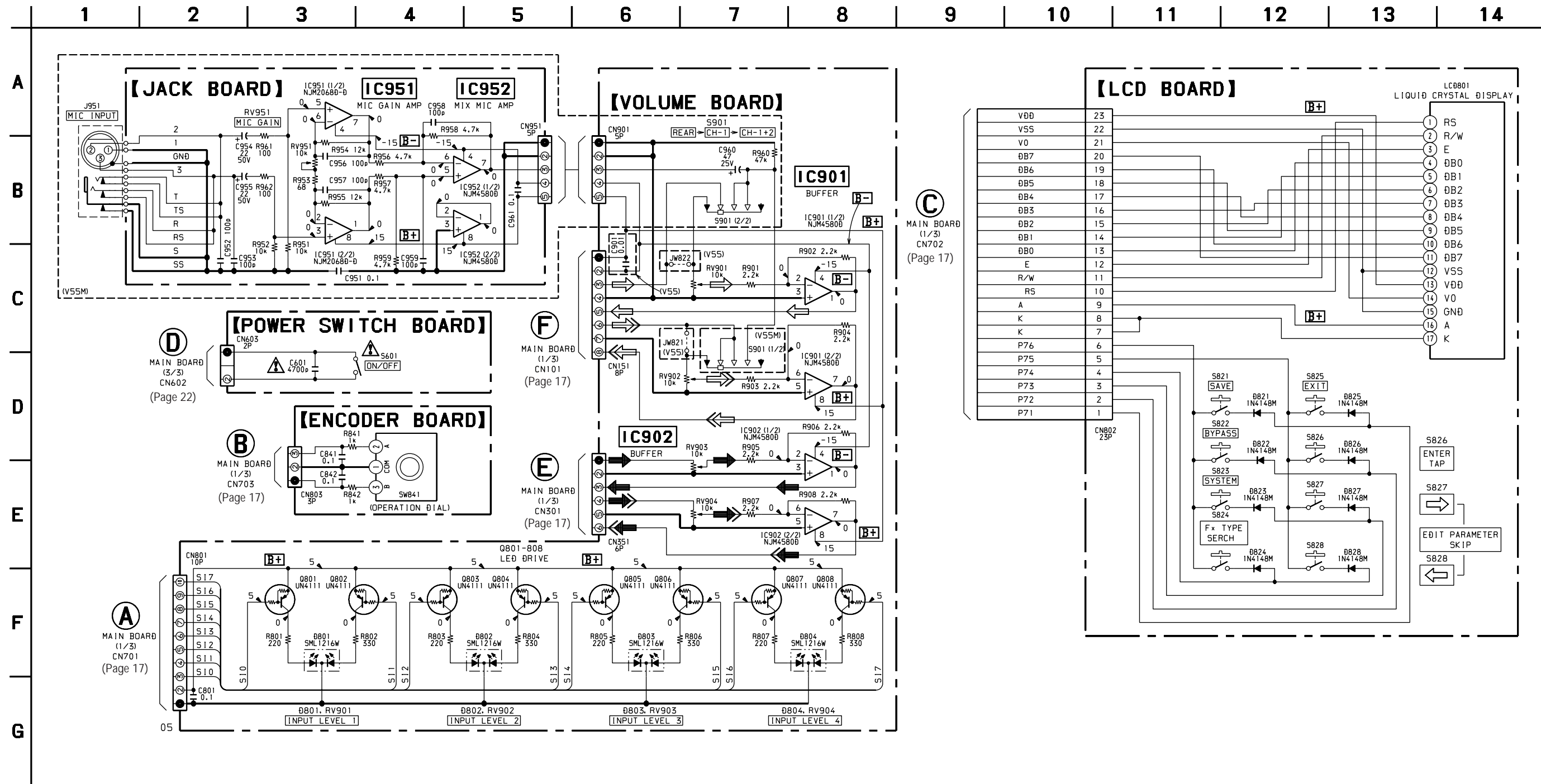

The components identified by mark Δ or dotted line with mark Δ are critical for safety. Replace only with part number specified.

Les composants identifiés par une marque Δ sont critiques pour la sécurité. Ne les remplacer que par une pièce portant le numéro spécifié.

• Waveforms
– MAIN BOARD –

① IC501 ③ (MCLK), IC551③ (MCLK)

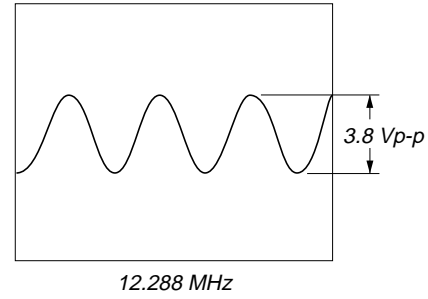

⑥ IC502 ⑳ (BCKO)

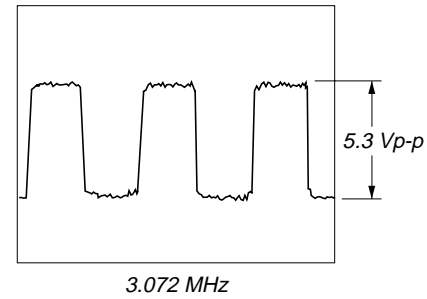

⑩ IC701 ㉔ (X0)

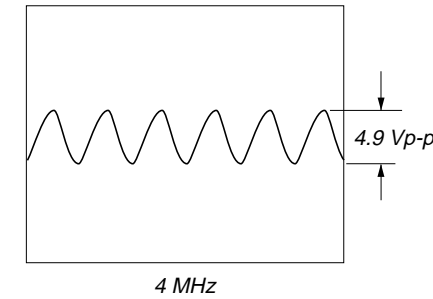

② IC501 ④ (LRCK), IC551 ④ (LRCK)

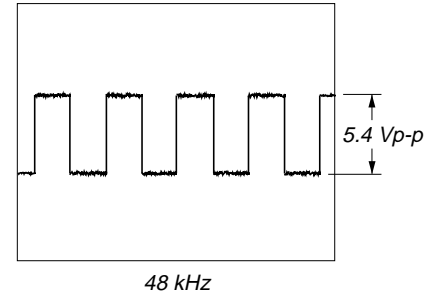

⑦ IC504 ② (OUT)

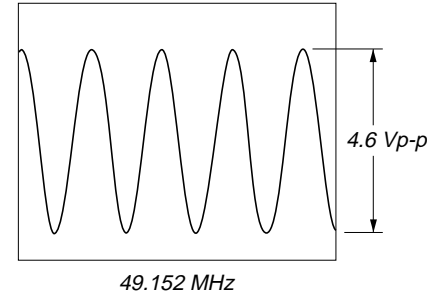

③ IC501 ⑤ (SCLK), IC551 ⑤ (SCLK)

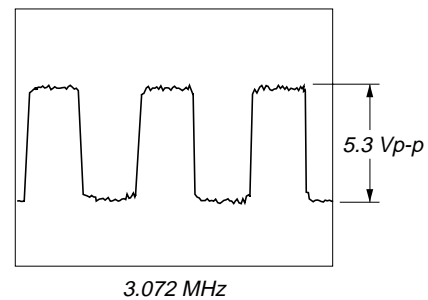

⑧ IC506 ② (CLK), IC507 ② (CLK)

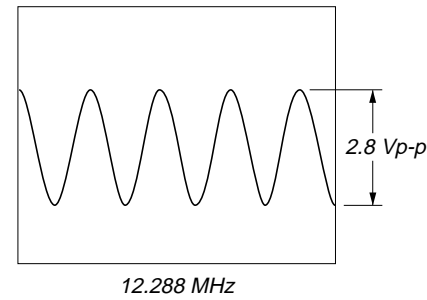

④ IC502 ⑬ (CLK0)

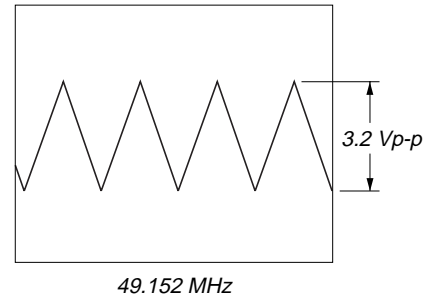

⑨ IC506 ⑬ (QB)

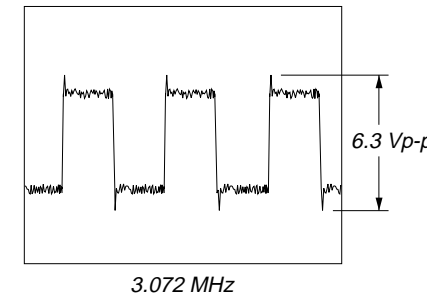

⑤ IC502 ⑰ (LRKO)

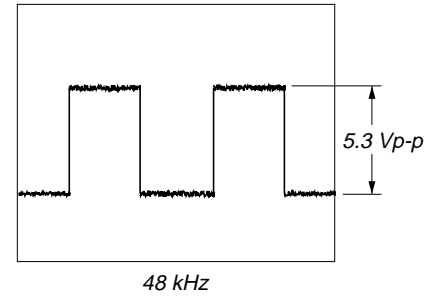

⑩ IC507 ⑰ (QD)

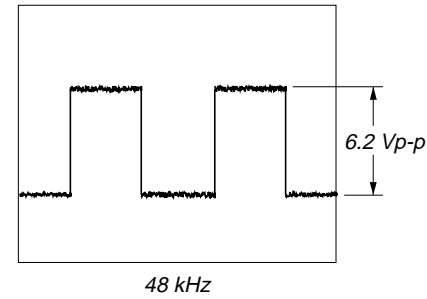

5-7. IC PIN FUNCTION DESCRIPTION

• MAIN BOARD IC502 CXD2707Q (DSP)

Pin No.	Pin Name	I/O	Function
1	EA9	O	Address signal output to the external RAM device Not used (open)
2	EC0	O	Address signal output to the memory (IC503)
3	VDD	—	Power supply terminal (+5V)
4	VSS	—	Ground terminal
5, 6	EC1, EC2	O	Address signal output to the external RAM device Not used (open)
7 to 9	EA13 to EA15	O	Address signal output to the external RAM device Not used (open)
10	TST	I	Input terminal for the test Not used (fixed at "L")
11	TDR	I	Input terminal for the test Not used (fixed at "L")
12	BFOT	O	Master clock buffer output terminal Not used (open)
13	CLKO	O	Master clock output terminal (49.152 MHz)
14	CLKI	I	Master clock input terminal (49.152 MHz)
15	VSS	—	Ground terminal
16	TS0	I	Input terminal for the test Not used (fixed at "L")
17	TS1	I	Input terminal for the test Not used (fixed at "L")
18	TSA	I	Input terminal for the test Not used (fixed at "L")
19	LRK0	I	L/R sampling clock signal input of the serial in/out data
20	LRK1	I	L/R sampling clock signal input of the serial in/out data Not used (fixed at "L")
21	BCK0	I	Bit clock signal input of the serial in/out data
22	BCK1	I	Bit clock signal input of the serial in/out data Not used (fixed at "L")
23	BCT	O	Divider output for the bit clock signal Not used (open)
24	LCT	I/O	Counter input for the cycle detect/divider LRCK output terminal Not used (open)
25	SIA	I	Serial data (for sound) input from the CS4222 (IC501)
26	SIB	I	Serial data (for sound) input from the CS4222 (IC551)
27	SIC	I	Serial data (for sound) input terminal Not used (fixed at "L")
28	VDD	—	Power supply terminal (+5V)
29	VSS	—	Ground terminal
30	SOA	O	Serial data (for sound) output to the CS4222 (IC501)
31	SOB	O	Serial data (for sound) output to the CS4222 (IC551)
32	SOC	O	Serial data (for sound) output terminal Not used (open)
33	ECJ0	I/O	Input for the jump condition/test data output terminal Not used (fixed at "L")
34	ECJ1	I/O	Input for the jump condition/test data output terminal Not used (fixed at "L")
35	ECJ2	I/O	Input for the jump condition/test data output terminal Not used (fixed at "L")
36	ECJ3	I/O	Input for the jump condition/test data output terminal Not used (fixed at "L")
37	REDY	O	Ready signal output to the CPU (IC701) "L": busy status
38	TRDT	O	Communication serial data output to the CPU (IC701)
39	XLAT	I	Serial data latch pulse input from the CPU (IC701)
40	VSS	—	Ground terminal
41	SCK	I	Communication serial data transfer clock signal input from the CPU (IC701)
42	RVDT	I	Communication serial data input from the CPU (IC701)
43	SCL0	O	Output terminal for the test Not used (open)
44	SCL1	O	Output terminal for the test Not used (open)
45	LR0F	O	Output terminal for the test Not used (open)
46	LR1F	O	Output terminal for the test Not used (open)
47	XRST	I	System reset signal input from the reset signal generator (IC703) "L": reset
48	ED0	I/O	Two-way data bus with the external RAM device Not used

Pin No.	Pin Name	I/O	Function
49	ED16	I/O	Two-way data bus with the memory (IC503)
50	ED1	I/O	Two-way data bus with the external RAM device Not used
51	ED17	I/O	Two-way data bus with the memory (IC503)
52	ED2	I/O	Two-way data bus with the external RAM device Not used
53	VDD	—	Power supply terminal (+5V)
54	VSS	—	Ground terminal
55	ED18	I/O	Two-way data bus with the memory (IC503)
56	ED3	I/O	Two-way data bus with the external RAM device Not used
57	ED19	I/O	Two-way data bus with the memory (IC503)
58	ED4	I/O	Two-way data bus with the external RAM device Not used
59	ED20	I/O	Two-way data bus with the memory (IC503)
60	ED5	I/O	Two-way data bus with the external RAM device Not used
61	ED21	I/O	Two-way data bus with the memory (IC503)
62	VSS	—	Ground terminal
63	ED6	I/O	Two-way data bus with the external RAM device Not used
64	ED22	I/O	Two-way data bus with the memory (IC503)
65	ED7	I/O	Two-way data bus with the external RAM device Not used
66	ED23	I/O	Two-way data bus with the memory (IC503)
67	ED8	I/O	Two-way data bus with the external RAM device Not used
68	ED24	I/O	Two-way data bus with the memory (IC503)
69	ED9	I/O	Two-way data bus with the external RAM device Not used
70	VSS	—	Ground terminal
71	ED25	I/O	Two-way data bus with the memory (IC503)
72	ED10	I/O	Two-way data bus with the external RAM device Not used
73	ED26	I/O	Two-way data bus with the memory (IC503)
74	ED11	I/O	Two-way data bus with the external RAM device Not used
75	ED27	I/O	Two-way data bus with the memory (IC503)
76	ED12	I/O	Two-way data bus with the external RAM device Not used
77	ED28	I/O	Two-way data bus with the memory (IC503)
78	VDD	—	Power supply terminal (+5V)
79	VSS	—	Ground terminal
80	ED13	I/O	Two-way data bus with the external RAM device Not used
81	ED29	I/O	Two-way data bus with the memory (IC503)
82	ED14	I/O	Two-way data bus with the external RAM device Not used
83	ED30	I/O	Two-way data bus with the memory (IC503)
84	ED15	I/O	Two-way data bus with the external RAM device Not used
85	ED31	I/O	Two-way data bus with the memory (IC503)
86	XOE	O	Output enable signal output to the memory (IC503)
87	VSS	—	Ground terminal
88	CAS	O	Column address strobe signal output to the memory (IC503)
89	XWE	O	Write enable signal output to the memory (IC503)
90	RAS	O	Row address strobe signal output to the memory (IC503)
91 to 94	EA0 to EA3	O	Address signal output to the memory (IC503)
95	VSS	—	Ground terminal
96 to 99	EA4 to EA7	O	Address signal output to the memory (IC503)
100	EA8	O	Address signal output to the external RAM device Not used (open)

• MAIN BOARD IC701 MB90641APF-G-105BND (CPU)

Pin No.	Pin Name	I/O	Function
1 to 10	A0 to A9	O	Address signal output to the static RAM (IC702) and EP-ROM (IC704)
11	VSS	—	Ground terminal
12 to 16	A10 to A14	O	Address signal output to the static RAM (IC702) and EP-ROM (IC704)
17, 18	A15, A16	O	Address signal output to the EP-ROM (IC704)
19 to 22	—	O	Not used (open)
23	VCC	—	Power supply terminal (+5V)
24 to 26	—	O	Not used (open)
27	C	—	Connected to capacitor
28 to 31	P71 to P74	I	Key return signal input terminal “L” active
32, 33	P75, P76	O	Key scan signal output terminal “L” active
34, 35	VCC	—	Power supply terminal (+5V)
36, 37	VSS	—	Ground terminal
38	P60	O	LED drive signal output for the INPUT LEVEL 1 LED (D801: red) “L”: LED on
39	P61	O	LED drive signal output for the INPUT LEVEL 1 LED (D801: green) “L”: LED on
40	P62	O	LED drive signal output for the INPUT LEVEL 2 LED (D802: red) “L”: LED on
41	P63	O	LED drive signal output for the INPUT LEVEL 2 LED (D802: green) “L”: LED on
42	VSS	—	Ground terminal
43	P64	O	LED drive signal output for the INPUT LEVEL 3 LED (D803: red) “L”: LED on
44	P65	O	LED drive signal output for the INPUT LEVEL 3 LED (D803: green) “L”: LED on
45	P66	O	LED drive signal output for the INPUT LEVEL 4 LED (D804: red) “L”: LED on
46	P67	O	LED drive signal output for the INPUT LEVEL 4 LED (D804: green) “L”: LED on
47	P80	I	Dial pulse input from the rotary encoder (SW841) “L” active
48	P81	I	Dial pulse input from the rotary encoder (SW841) “L” active
49	MD0	I	Setting terminal for the external vector mode Fixed at “L” in this set
50	MD1	I	Setting terminal for the external vector mode Fixed at “H” in this set
51	MD2	I	Setting terminal for the external vector mode Fixed at “L” in this set
52	HSTX	I	Hardware standby input terminal Fixed at “H” in this set
53	REDY	I	Ready detection signal input from the DSP (IC502) “L”: busy status
54	XLAT	O	Serial data latch pulse output to the DSP (IC502)
55	TRDT	I	UART serial data input from the DSP (IC502)
56	RVDT	O	UART serial data output to the DSP (IC502)
57	SCK	O	UART serial data transfer clock signal output to the DSP (IC502)
58	MIDI IN	I	Input terminal for the MIDI connection
59	MIDI OUT	O	Output terminal for the MIDI connection
60	BATT CHK	I	Voltage detection input for the lithium battery (BA701) “L”: no battery
61	OUTPUT MUTE	O	Muting on/off selection signal output for the analog output circuit “H”: muting on
62, 63	—	O	Not used (open)
64	CS0	O	Chip select signal output to the EP-ROM (IC704) “L” active
65	CS1	O	Chip select signal output to the static RAM (IC702) “L” active
66	LCD CONTRAST ON	O	Control signal output to the liquid crystal display contrast adjustment circuit “H”: contrast on
67	ADMUTE	O	Muting control signal output to the A/D converter (IC501, 551) “L”: muting on
68	ADLAT	O	Serial data latch pulse output to the A/D converter (IC501, 551)
69	ADCLK	O	Serial data transfer clock signal output to the A/D converter (IC501, 551)
70	ADDAT	O	Serial data output to the A/D converter (IC501, 551)
71, 72	—	O	Not used (open)

Pin No.	Pin Name	I/O	Function
73	RS	O	Register selection signal output to the LCD module (LCD801)
74	R/W	O	Data read/write selection signal output to the LCD module (LCD801)
75	E	O	Enable signal output to the LCD module (LCD801)
76	—	O	Not used (open)
77	RSTX	I	Reset signal input terminal “L”: reset
78	WR	O	Write strobe signal output to the static RAM (IC702)
79	RD	O	Read strobe signal output to the static RAM (IC702) and EP-ROM (IC704)
80	—	O	Not used (open)
81	VSS	—	Ground terminal
82	X0	I	System clock input terminal (4 MHz)
83	X1	O	System clock output terminal (4 MHz)
84	VCC	—	Power supply terminal (+5V)
85 to 92	D00 to D07	I/O	Two-way data bus with the static RAM (IC702) and EP-ROM (IC704)
93 to 100	P10 to P17	I/O	Two-way data bus with the LCD module (LCD801)

SECTION 6 EXPLODED VIEWS

NOTE:

- -XX and -X mean standardized parts, so they may have some difference from the original one.
- Color Indication of Appearance Parts
Example:
KNOB, BALANCE (WHITE) . . . (RED)
 ↑ ↑
 Parts Color Cabinet's Color

- Items marked “*” are not stocked since they are seldom required for routine service. Some delay should be anticipated when ordering these items.
- The mechanical parts with no reference number in the exploded views are not supplied.
- Hardware (# mark) list and accessories and packing materials are given in the last of the electrical parts list.

The components identified by mark Δ or dotted line with mark Δ are critical for safety. Replace only with part number specified.

Les composants identifiés par une marque Δ sont critiques pour la sécurité. Ne les remplacer que par une pièce portant le numéro spécifié.

(1) CASE, FRONT PANEL SECTION

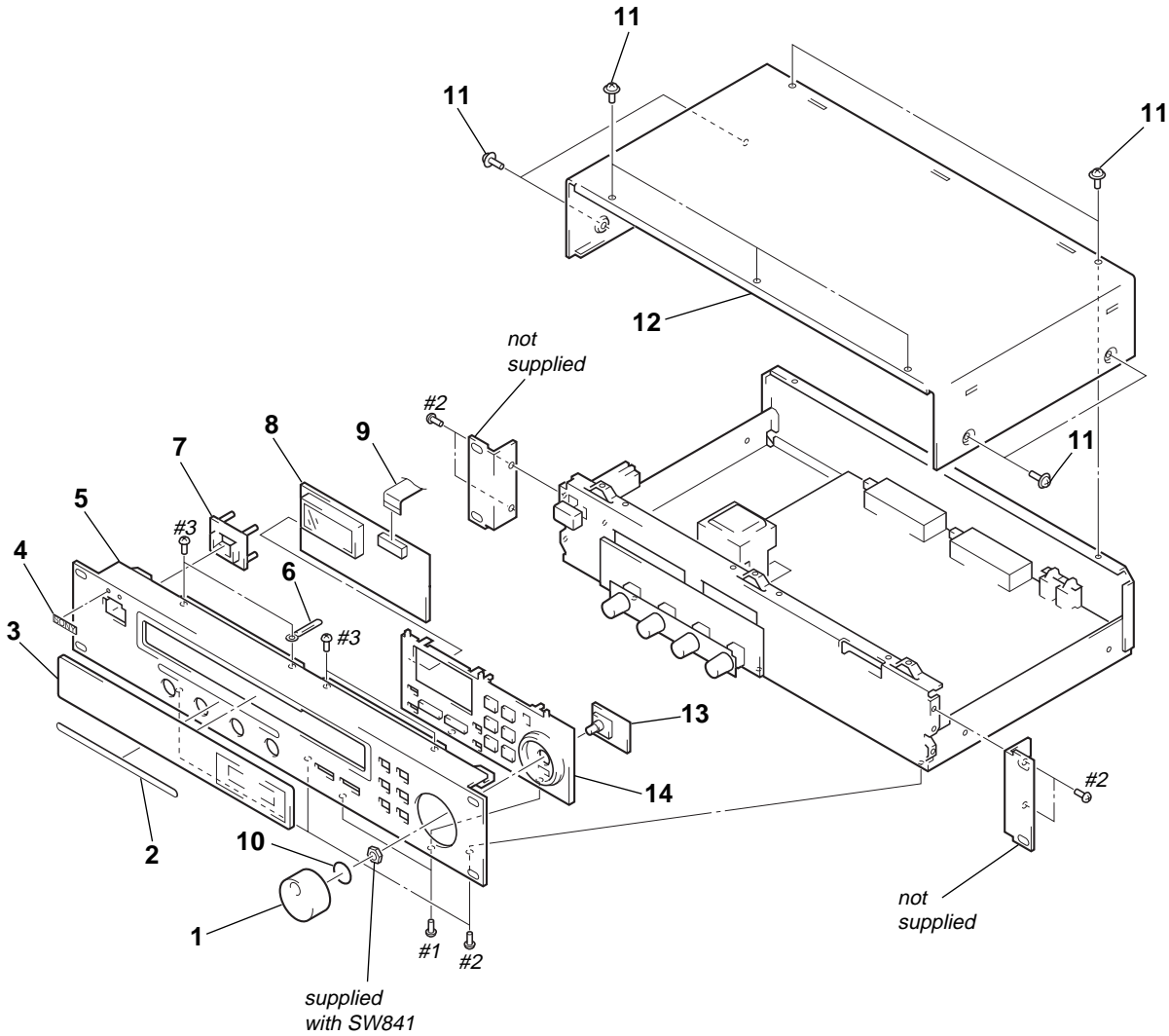

Ref. No.	Part No.	Description	Remark	Ref. No.	Part No.	Description	Remark
1	4-997-526-01	KNOB (JOG)		* 8	1-668-985-11	LCD BOARD	
2	4-997-525-01	WINDOW (LED), INDICATION		9	1-773-178-11	WIRE (FLAT TYPE) (23 CORE)	
3	4-997-524-01	WINDOW (LCD), INDICATION		10	4-988-161-01	SPRING, RING	
4	4-908-848-31	EMBLEM, SONY		11	3-363-099-21	SCREW (CASE 3 TP2)	
5	4-997-528-01	PANEL, FRONT (DPS-V55)		* 12	4-997-712-01	CASE	
5	4-997-528-11	PANEL, FRONT (DPS-V55M)		* 13	1-668-986-11	ENCODER BOARD	
* 6	3-703-150-11	CLAMP		14	4-997-523-01	BASE, PANEL	
7	4-941-139-01	ESCUTCHEON (A)					

(2) CHASSIS SECTION

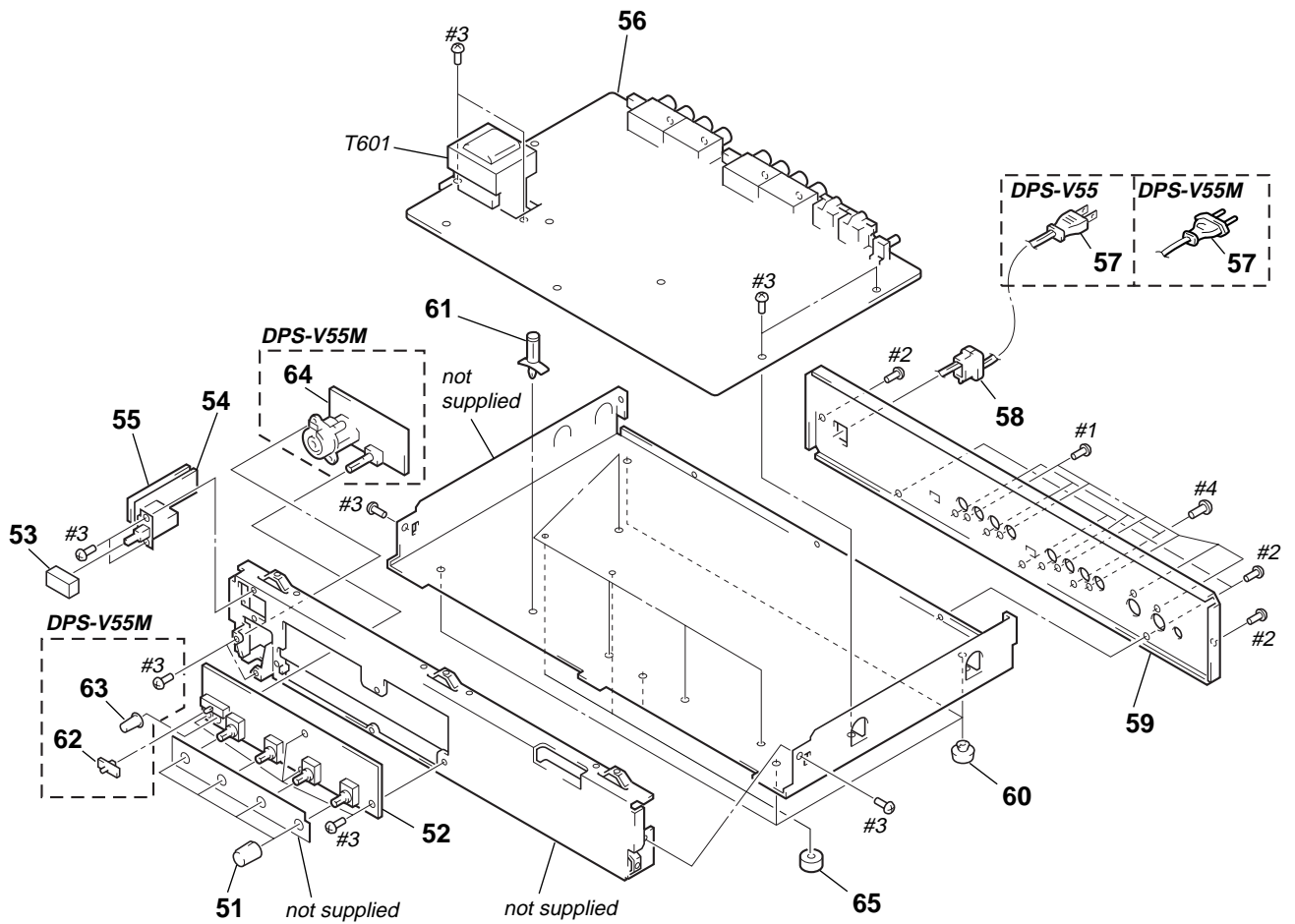

<p>The components identified by mark Δ or dotted line with mark Δ are critical for safety. Replace only with part number specified.</p>	<p>Les composants identifiés par une marque Δ sont critiques pour la sécurité. Ne les remplacer que par une pièce portant le numéro spécifié.</p>
---	---

Ref. No.	Part No.	Description	Remark	Ref. No.	Part No.	Description	Remark
51	4-985-926-21	KNOB		* 59	4-997-529-21	PANEL, BACK (DPS-V55M)	
* 52	1-668-987-11	VOLUME BOARD		60	3-670-155-11	LEG	
53	4-922-921-81	BUTTON (POWER)		* 61	3-670-570-00	SPACER, SUPPORT	
* 54	1-668-989-11	POWER SWITCH BOARD		62	3-917-216-11	KNOB (TIMER) (DPS-V55M)	
* 55	1-668-990-11	POWER COVER BOARD		63	4-985-896-11	KNOB (REC) (DPS-V55M)	
* 56	A-4407-336-A	MAIN BOARD, COMPLETE		* 64	1-668-988-11	JACK BOARD (DPS-V55M)	
Δ 57	1-575-651-21	CORD, POWER (DPS-V55M)		* 65	4-999-176-01	CUSION (DIA.10)	
Δ 57	1-590-836-11	CORD, POWER (DPS-V55)		Δ T601	1-431-768-11	TRANSFORMER, POWER (DPS-V55M)	
58	3-703-244-00	BUSHING (2104), CORD		Δ T601	1-431-769-11	TRANSFORMER, POWER (DPS-V55)	
* 59	4-997-529-11	PANEL, BACK (DPS-V55)					

SECTION 7 ELECTRICAL PARTS LIST

NOTE:

- Due to standardization, replacements in the parts list may be different from the parts specified in the diagrams or the components used on the set.
- -XX and -X mean standardized parts, so they may have some difference from the original one.
- RESISTORS
All resistors are in ohms.
METAL: Metal-film resistor.
METAL OXIDE: Metal oxide-film resistor.
F: nonflammable

- Items marked “**” are not stocked since they are seldom required for routine service. Some delay should be anticipated when ordering these items.
- SEMICONDUCTORS
In each case, u: μ , for example:
uA. . . : μ A. . . uPA. . . : μ PA. . .
uPB. . . : μ PB. . . uPC. . . : μ PC. . .
uPD. . . : μ PD. . .
- CAPACITORS
uF: μ F
- COILS
uH: μ H

The components identified by mark Δ or dotted line with mark Δ are critical for safety. Replace only with part number specified.

Les composants identifiés par une marque Δ sont critiques pour la sécurité. Ne les remplacer que par une pièce portant le numéro spécifié.

When indicating parts by reference number, please include the board.

Ref. No.	Part No.	Description	Remark	Ref. No.	Part No.	Description	Remark
*	1-668-986-11	ENCODER BOARD *****				< RESISTOR >	
		< CAPACITOR >		R951	1-259-452-11	CARBON 10K 5% 1/6W	
				R952	1-259-452-11	CARBON 10K 5% 1/6W	
C841	1-164-159-11	CERAMIC 0.1uF	50V	R953	1-259-400-11	CARBON 68 5% 1/6W	
C842	1-164-159-11	CERAMIC 0.1uF	50V	R954	1-259-454-11	CARBON 12K 5% 1/6W	
		< RESISTOR >		R955	1-259-454-11	CARBON 12K 5% 1/6W	
R841	1-249-417-11	CARBON 1K 5%	1/4W	R956	1-259-444-11	CARBON 4.7K 5% 1/6W	
R842	1-249-417-11	CARBON 1K 5%	1/4W	R957	1-259-444-11	CARBON 4.7K 5% 1/6W	
		< SWITCH >		R958	1-259-444-11	CARBON 4.7K 5% 1/6W	
SW841	1-467-968-11	ENCODER, ROTARY (OPERATION DIAL)		R959	1-259-444-11	CARBON 4.7K 5% 1/6W	
*****				R961	1-259-404-11	CARBON 100 5% 1/6W	
		< CAPACITOR >		R962	1-259-404-11	CARBON 100 5% 1/6W	
*	1-668-988-11	JACK BOARD (DPS-V55M) *****				< VARIABLE RESISTOR >	
		< CAPACITOR >		RV951	1-225-604-11	RES, VAR 10K (MIC GAIN)	
C951	1-164-159-11	CERAMIC 0.1uF	50V	*****			
C952	1-162-282-31	CERAMIC 100PF	10% 50V	*	1-668-985-11	LCD BOARD *****	
C953	1-162-282-31	CERAMIC 100PF	10% 50V			< CONNECTOR >	
C954	1-126-049-11	ELECT 22uF	20% 50V	* CN802	1-568-865-11	SOCKET, CONNECTOR 23P	
C955	1-126-049-11	ELECT 22uF	20% 50V			< DIODE >	
C956	1-110-335-11	MYLAR 100PF	5% 50V	D821	8-719-911-19	DIODE 1SS119	
C957	1-110-335-11	MYLAR 100PF	5% 50V	D822	8-719-911-19	DIODE 1SS119	
C958	1-110-335-11	MYLAR 100PF	5% 50V	D823	8-719-911-19	DIODE 1SS119	
C959	1-110-335-11	MYLAR 100PF	5% 50V	D824	8-719-911-19	DIODE 1SS119	
C961	1-136-165-00	FILM 0.1uF	5% 50V	D825	8-719-911-19	DIODE 1SS119	
		< CONNECTOR >		D826	8-719-911-19	DIODE 1SS119	
CN951	1-779-830-11	CONNECTOR, BOARD TO BOARD 5P		D827	8-719-911-19	DIODE 1SS119	
		< IC >		D828	8-719-911-19	DIODE 1SS119	
IC951	8-759-701-25	IC NJM2068D-D				< LIQUID CRYSTAL DISPLAY >	
IC952	8-759-711-35	IC NJM4580D		LCD801	1-801-750-11	DISPLAY PANEL, LIQUID CRYSTAL	
		< JACK >				< SWITCH >	
J951	1-784-668-11	JACK (MIC INPUT)		S821	1-554-303-21	SWITCH, TACTILE (SAVE)	
				S822	1-554-303-21	SWITCH, TACTILE (BYPASS)	
				S823	1-554-303-21	SWITCH, TACTILE (SYSTEM)	
				S824	1-554-303-21	SWITCH, TACTILE (FxTYPE SEARCH)	

Ref. No.	Part No.	Description	Remark	Ref. No.	Part No.	Description	Remark
S825	1-554-303-21	SWITCH, TACTILE (EXIT)		C312	1-110-339-11	MYLAR 220PF 5%	50V
S826	1-554-303-21	SWITCH, TACTILE (ENTER TAP)		C313	1-130-475-00	MYLAR 0.0022uF 5%	50V
S827	1-554-303-21	SWITCH, TACTILE (EDIT PARAMETER SKIP ⇐)		C314	1-126-022-11	ELECT 47uF 20%	25V
S828	1-554-303-21	SWITCH, TACTILE (EDIT PARAMETER SKIP ⇐)		C315	1-163-133-00	CERAMIC CHIP 470PF 5%	50V
*****				C318	1-110-335-11	MYLAR 100PF 5%	50V
*	A-4407-336-A	MAIN BOARD, COMPLETE	*****	C319	1-130-474-00	MYLAR 0.0018uF 5%	50V
	1-540-107-11	SOCKET, IC 32P		C320	1-130-475-00	MYLAR 0.0022uF 5%	50V
	7-685-872-09	SCREW +BVTT 3X8 (S)		C351	1-115-339-11	CERAMIC CHIP 0.1uF 10%	50V
		< BATTERY HOLDER >		C402	1-126-022-11	ELECT 47uF 20%	25V
BA701	1-550-414-21	HOLDER, BATTERY		C403	1-163-251-11	CERAMIC CHIP 100PF 5%	50V
		< CAPACITOR >		C404	1-110-335-11	MYLAR 100PF 5%	50V
C102	1-126-022-11	ELECT 47uF 20%	25V	C405	1-110-335-11	MYLAR 100PF 5%	50V
C103	1-163-251-11	CERAMIC CHIP 100PF 5%	50V	C406	1-126-022-11	ELECT 47uF 20%	25V
C104	1-110-335-11	MYLAR 100PF 5%	50V	C407	1-126-022-11	ELECT 47uF 20%	25V
C105	1-110-335-11	MYLAR 100PF 5%	50V	C410	1-110-335-11	MYLAR 100PF 5%	50V
C106	1-126-022-11	ELECT 47uF 20%	25V	C411	1-110-335-11	MYLAR 100PF 5%	50V
C107	1-126-022-11	ELECT 47uF 20%	25V	C412	1-110-339-11	MYLAR 220PF 5%	50V
C110	1-110-335-11	MYLAR 100PF 5%	50V	C413	1-130-475-00	MYLAR 0.0022uF 5%	50V
C111	1-110-335-11	MYLAR 100PF 5%	50V	C414	1-126-022-11	ELECT 47uF 20%	25V
C112	1-110-339-11	MYLAR 220PF 5%	50V	C415	1-163-133-00	CERAMIC CHIP 470PF 5%	50V
C113	1-130-475-00	MYLAR 0.0022uF 5%	50V	C418	1-110-335-11	MYLAR 100PF 5%	50V
C114	1-126-022-11	ELECT 47uF 20%	25V	C419	1-130-474-00	MYLAR 0.0018uF 5%	50V
C115	1-163-133-00	CERAMIC CHIP 470PF 5%	50V	C420	1-130-475-00	MYLAR 0.0022uF 5%	50V
C116	1-136-165-00	FILM 0.1uF 5%	50V	C501	1-126-025-11	ELECT 330uF 20%	16V
C117	1-136-165-00	FILM 0.1uF 5%	50V	C502	1-115-339-11	CERAMIC CHIP 0.1uF 10%	50V
C118	1-110-335-11	MYLAR 100PF 5%	50V	C503	1-126-025-11	ELECT 330uF 20%	16V
C119	1-130-474-00	MYLAR 0.0018uF 5%	50V	C504	1-136-165-00	FILM 0.1uF 5%	50V
C120	1-130-475-00	MYLAR 0.0022uF 5%	50V	C505	1-126-047-81	ELECT 4.7uF 20%	50V
C151	1-115-339-11	CERAMIC CHIP 0.1uF 10%	50V	C506	1-136-165-00	FILM 0.1uF 5%	50V
C153	1-126-964-11	ELECT 10uF 20%	50V	C508	1-115-339-11	CERAMIC CHIP 0.1uF 10%	50V
C202	1-126-022-11	ELECT 47uF 20%	25V	C509	1-115-339-11	CERAMIC CHIP 0.1uF 10%	50V
C203	1-163-251-11	CERAMIC CHIP 100PF 5%	50V	C514	1-126-934-11	ELECT 220uF 20%	10V
C204	1-110-335-11	MYLAR 100PF 5%	50V	C515	1-115-339-11	CERAMIC CHIP 0.1uF 10%	50V
C205	1-110-335-11	MYLAR 100PF 5%	50V	C516	1-115-339-11	CERAMIC CHIP 0.1uF 10%	50V
C206	1-126-022-11	ELECT 47uF 20%	25V	C517	1-115-339-11	CERAMIC CHIP 0.1uF 10%	50V
C207	1-126-022-11	ELECT 47uF 20%	25V	C518	1-115-339-11	CERAMIC CHIP 0.1uF 10%	50V
C210	1-110-335-11	MYLAR 100PF 5%	50V	C519	1-115-339-11	CERAMIC CHIP 0.1uF 10%	50V
C211	1-110-335-11	MYLAR 100PF 5%	50V	C520	1-126-934-11	ELECT 220uF 20%	10V
C212	1-110-339-11	MYLAR 220PF 5%	50V	C521	1-115-339-11	CERAMIC CHIP 0.1uF 10%	50V
C213	1-130-475-00	MYLAR 0.0022uF 5%	50V	C523	1-115-339-11	CERAMIC CHIP 0.1uF 10%	50V
C214	1-126-022-11	ELECT 47uF 20%	25V	C524	1-163-220-11	CERAMIC CHIP 3PF 0.25PF	50V
C215	1-163-133-00	CERAMIC CHIP 470PF 5%	50V	C525	1-163-087-00	CERAMIC CHIP 4PF 0.5PF	50V
C218	1-110-335-11	MYLAR 100PF 5%	50V	C527	1-115-339-11	CERAMIC CHIP 0.1uF 10%	50V
C219	1-130-474-00	MYLAR 0.0018uF 5%	50V	C529	1-115-339-11	CERAMIC CHIP 0.1uF 10%	50V
C220	1-130-475-00	MYLAR 0.0022uF 5%	50V	C530	1-163-009-11	CERAMIC CHIP 0.001uF 10%	50V
C302	1-126-022-11	ELECT 47uF 20%	25V	C531	1-115-339-11	CERAMIC CHIP 0.1uF 10%	50V
C303	1-163-251-11	CERAMIC CHIP 100PF 5%	50V	C532	1-115-339-11	CERAMIC CHIP 0.1uF 10%	50V
C304	1-110-335-11	MYLAR 100PF 5%	50V	C551	1-126-025-11	ELECT 330uF 20%	16V
C305	1-110-335-11	MYLAR 100PF 5%	50V	C552	1-115-339-11	CERAMIC CHIP 0.1uF 10%	50V
C306	1-126-022-11	ELECT 47uF 20%	25V	C553	1-126-025-11	ELECT 330uF 20%	16V
C307	1-126-022-11	ELECT 47uF 20%	25V	C554	1-136-165-00	FILM 0.1uF 5%	50V
C310	1-110-335-11	MYLAR 100PF 5%	50V	C555	1-126-047-81	ELECT 4.7uF 20%	50V
C311	1-110-335-11	MYLAR 100PF 5%	50V	C556	1-136-165-00	FILM 0.1uF 5%	50V
				C558	1-115-339-11	CERAMIC CHIP 0.1uF 10%	50V
				C559	1-115-339-11	CERAMIC CHIP 0.1uF 10%	50V
				△C602	1-117-703-11	CERAMIC 0.0047uF 99%	250V
				C604	1-126-943-11	ELECT 2200uF 20%	25V
				C605	1-126-943-11	ELECT 2200uF 20%	25V

The components identified by mark Δ or dotted line with mark Δ are critical for safety. Replace only with part number specified.

Les composants identifiés par une marque Δ sont critiques pour la sécurité. Ne les remplacer que par une pièce portant le numéro spécifié.

MAIN

Ref. No.	Part No.	Description	Remark	Ref. No.	Part No.	Description	Remark
C606	1-136-165-00	FILM	0.1uF 5%	50V	CN703	1-506-468-11	PIN, CONNECTOR 3P
C607	1-136-165-00	FILM	0.1uF 5%	50V			
C608	1-136-165-00	FILM	0.1uF 5%	50V		< DIODE >	
C609	1-136-165-00	FILM	0.1uF 5%	50V			
C610	1-136-165-00	FILM	0.1uF 5%	50V	D101	8-719-911-19	DIODE 1SS119
					D102	8-719-911-19	DIODE 1SS119
C611	1-136-165-00	FILM	0.1uF 5%	50V	D103	8-719-911-19	DIODE 1SS119
C612	1-126-023-11	ELECT	100uF 20%	25V	D104	8-719-911-19	DIODE 1SS119
C613	1-126-023-11	ELECT	100uF 20%	25V	D151	8-719-911-19	DIODE 1SS119
C616	1-126-943-11	ELECT	2200uF 20%	25V			
C618	1-115-339-11	CERAMIC CHIP	0.1uF 10%	50V	D201	8-719-911-19	DIODE 1SS119
					D202	8-719-911-19	DIODE 1SS119
C619	1-126-943-11	ELECT	2200uF 20%	25V	D203	8-719-911-19	DIODE 1SS119
C620	1-126-943-11	ELECT	2200uF 20%	25V	D204	8-719-911-19	DIODE 1SS119
C621	1-115-339-11	CERAMIC CHIP	0.1uF 10%	50V	D301	8-719-911-19	DIODE 1SS119
C622	1-115-339-11	CERAMIC CHIP	0.1uF 10%	50V			
C623	1-115-339-11	CERAMIC CHIP	0.1uF 10%	50V	D302	8-719-911-19	DIODE 1SS119
					D303	8-719-911-19	DIODE 1SS119
C624	1-115-339-11	CERAMIC CHIP	0.1uF 10%	50V	D304	8-719-911-19	DIODE 1SS119
C625	1-126-943-11	ELECT	2200uF 20%	25V	D401	8-719-911-19	DIODE 1SS119
C626	1-126-943-11	ELECT	2200uF 20%	25V	D402	8-719-911-19	DIODE 1SS119
C627	1-115-339-11	CERAMIC CHIP	0.1uF 10%	50V			
C651	1-126-964-11	ELECT	10uF 20%	50V	D403	8-719-911-19	DIODE 1SS119
					D404	8-719-911-19	DIODE 1SS119
C701	1-126-933-11	ELECT	100uF 20%	10V	D601	8-719-200-02	DIODE 10E2
C702	1-115-339-11	CERAMIC CHIP	0.1uF 10%	50V	D602	8-719-200-02	DIODE 10E2
C703	1-115-339-11	CERAMIC CHIP	0.1uF 10%	50V	D603	8-719-200-02	DIODE 10E2
C704	1-115-339-11	CERAMIC CHIP	0.1uF 10%	50V			
C705	1-115-339-11	CERAMIC CHIP	0.1uF 10%	50V	D604	8-719-200-02	DIODE 10E2
					D605	8-719-200-02	DIODE 10E2
C706	1-115-339-11	CERAMIC CHIP	0.1uF 10%	50V	D606	8-719-200-02	DIODE 10E2
C709	1-126-967-11	ELECT	47uF 20%	16V	D607	8-719-200-02	DIODE 10E2
C710	1-115-339-11	CERAMIC CHIP	0.1uF 10%	50V	D608	8-719-200-02	DIODE 10E2
C712	1-115-339-11	CERAMIC CHIP	0.1uF 10%	50V			
C713	1-163-227-11	CERAMIC CHIP	10PF 0.5PF	50V	D609	8-719-911-19	DIODE 1SS119
					D610	8-719-911-19	DIODE 1SS119
C714	1-126-933-11	ELECT	100uF 20%	10V	D651	8-719-200-82	DIODE 11ES2
C715	1-115-339-11	CERAMIC CHIP	0.1uF 10%	50V	D652	8-719-200-82	DIODE 11ES2
C716	1-126-933-11	ELECT	100uF 20%	10V	D701	8-719-911-19	DIODE 1SS119
C717	1-115-339-11	CERAMIC CHIP	0.1uF 10%	50V			
C718	1-126-933-11	ELECT	100uF 20%	10V	D751	8-719-911-19	DIODE 1SS119
						< FERRITE BEAD >	
C719	1-115-339-11	CERAMIC CHIP	0.1uF 10%	50V	FB501	1-414-766-21	INDUCTOR CHIP 0uH
C720	1-115-339-11	CERAMIC CHIP	0.1uF 10%	50V	FB502	1-414-766-21	INDUCTOR CHIP 0uH
C722	1-164-232-11	CERAMIC CHIP	0.01uF	50V	FB601	1-410-397-21	FERRITE BEAD INDUCTOR 1.1uH
C723	1-115-339-11	CERAMIC CHIP	0.1uF 10%	50V	FB602	1-410-397-21	FERRITE BEAD INDUCTOR 1.1uH
C751	1-115-339-11	CERAMIC CHIP	0.1uF 10%	50V	FB603	1-410-397-21	FERRITE BEAD INDUCTOR 1.1uH
C752	1-115-339-11	CERAMIC CHIP	0.1uF 10%	50V	FB751	1-410-397-21	FERRITE BEAD INDUCTOR 1.1uH
C753	1-126-933-11	ELECT	100uF 20%	10V	FB752	1-410-397-21	FERRITE BEAD INDUCTOR 1.1uH
C754	1-115-339-11	CERAMIC CHIP	0.1uF 10%	50V			
C755	1-115-339-11	CERAMIC CHIP	0.1uF 10%	50V			
C756	1-115-339-11	CERAMIC CHIP	0.1uF 10%	50V			
						< IC >	
C757	1-115-339-11	CERAMIC CHIP	0.1uF 10%	50V	IC101	8-759-711-82	IC NJM4580E
C758	1-115-339-11	CERAMIC CHIP	0.1uF 10%	50V	IC102	8-759-711-82	IC NJM4580E
C759	1-115-339-11	CERAMIC CHIP	0.1uF 10%	50V	IC103	8-759-711-82	IC NJM4580E
C760	1-115-339-11	CERAMIC CHIP	0.1uF 10%	50V	IC104	8-759-711-82	IC NJM4580E
C761	1-115-339-11	CERAMIC CHIP	0.1uF 10%	50V	IC201	8-759-711-82	IC NJM4580E
					IC202	8-759-711-82	IC NJM4580E
					IC203	8-759-711-82	IC NJM4580E
					IC301	8-759-711-82	IC NJM4580E
					IC302	8-759-711-82	IC NJM4580E
					IC303	8-759-711-82	IC NJM4580E
					IC304	8-759-711-82	IC NJM4580E
					IC401	8-759-711-82	IC NJM4580E
CN101	1-564-511-11	PLUG, CONNECTOR 8P					
* CN301	1-564-509-11	PLUG, CONNECTOR 6P					
CN601	1-580-230-11	PIN, CONNECTOR (PC BOARD) 2P					
CN602	1-580-230-51	PIN, CONNECTOR (PC BOARD) 2P					
* CN701	1-568-937-11	PIN, CONNECTOR 10P					
* CN702	1-568-839-11	SOCKET, CONNECTOR 23P					

Ref. No.	Part No.	Description	Remark	Ref. No.	Part No.	Description	Remark
IC402	8-759-711-82	IC NJM4580E		L701	1-410-521-11	INDUCTOR 100uH	
IC403	8-759-711-82	IC NJM4580E		L702	1-410-521-11	INDUCTOR 100uH	
IC501	8-759-530-36	IC CS4222-KS		L703	1-410-521-11	INDUCTOR 100uH	
IC502	8-752-362-00	IC CXD2707Q		L704	1-410-521-11	INDUCTOR 100uH	
IC503	8-759-368-97	IC M5M44260CTP-7S		L751	1-410-521-11	INDUCTOR 100uH	
IC504	8-759-233-64	IC TC74HCU04AF				< LINE FILTER >	
IC505	8-759-186-39	IC TC74VHC74F		△LF601	1-424-485-11	FILTER, LINE	
IC506	8-759-037-79	IC MC74HC163AF				< PHOTO INTERRUPTER >	
IC507	8-759-037-79	IC MC74HC163AF		PH751	8-749-924-58	PHOTO COUPLER PC900V	
IC551	8-759-530-36	IC CS4222-KS				< TRANSISTOR >	
IC601	8-759-982-36	IC RC78M15FA		Q101	8-729-141-30	TRANSISTOR 2SC3623A-LK	
IC602	8-759-701-70	IC NJM79M15FA		Q151	8-729-900-65	TRANSISTOR DTA144ES	
IC603	8-759-701-56	IC NJM78M05FA		Q152	8-729-900-89	TRANSISTOR DTC144ES	
IC604	8-759-701-56	IC NJM78M05FA		Q201	8-729-141-30	TRANSISTOR 2SC3623A-LK	
IC701	8-759-488-56	IC MB90641APF-G-105BND		Q301	8-729-141-30	TRANSISTOR 2SC3623A-LK	
IC702	8-759-491-96	IC CY62256LL-70SNC-T2		Q401	8-729-141-30	TRANSISTOR 2SC3623A-LK	
IC703	8-759-637-07	IC M62021FP-600C		Q651	8-729-900-89	TRANSISTOR DTC144ES	
IC704	8-759-499-74	IC MX27C1000DC-90-V55-10		Q652	8-729-900-89	TRANSISTOR DTC144ES	
IC705	8-759-635-00	IC M5239L		Q701	8-729-141-30	TRANSISTOR 2SC3623A-LK	
		< JACK >		Q702	8-729-422-73	TRANSISTOR UN4212	
J101	1-750-973-11	JACK (LARGE TYPE) (2 GANG) (INPUT GROUP A, 1 (MONO) /2)		Q703	8-729-119-76	TRANSISTOR 2SA1175-HFE	
J102	1-750-973-11	JACK (LARGE TYPE) (2 GANG) (OUTPUT GROUP A, 1 (MONO) /2)		Q704	8-729-119-76	TRANSISTOR 2SA1175-HFE	
J301	1-750-973-11	JACK (LARGE TYPE) (2 GANG) (INPUT GROUP B, 3 (MONO) /4)		Q751	8-729-900-89	TRANSISTOR DTC144ES	
J302	1-750-973-11	JACK (LARGE TYPE) (2 GANG) (OUTPUT GROUP B, 3 (MONO) /4)		Q752	8-729-900-89	TRANSISTOR DTC144ES	
J751	1-750-971-11	CONNECTOR, DIN 5P (MIDI IN, OUT/THRU)		Q753	8-729-900-65	TRANSISTOR DTA144ES	
		< JUMPER RESISTOR >				< RESISTOR >	
JR003	1-216-296-00	SHORT (CHIP) 0		R102	1-216-238-00	RES,CHIP 47K 2% 1/8W	
JR004	1-216-296-00	SHORT (CHIP) 0		R103	1-216-174-00	RES,CHIP 100 2% 1/8W	
JR005	1-216-296-00	SHORT (CHIP) 0		R104	1-208-510-61	RES,CHIP 10K 2% 1/8W	
JR006	1-216-296-00	SHORT (CHIP) 0		R105	1-208-510-61	RES,CHIP 10K 2% 1/8W	
JR009	1-216-296-00	SHORT (CHIP) 0		R106	1-216-214-00	RES,CHIP 4.7K 2% 1/8W	
JR010	1-216-295-00	SHORT (CHIP) 0		R107	1-216-214-00	RES,CHIP 4.7K 2% 1/8W	
JR011	1-216-295-00	SHORT (CHIP) 0		R108	1-208-510-61	RES,CHIP 10K 2% 1/8W	
JR012	1-216-295-00	SHORT (CHIP) 0		R109	1-208-510-61	RES,CHIP 10K 2% 1/8W	
JR013	1-216-295-00	SHORT (CHIP) 0		R110	1-208-510-61	RES,CHIP 10K 2% 1/8W	
JR014	1-216-295-00	SHORT (CHIP) 0		R111	1-208-510-61	RES,CHIP 10K 2% 1/8W	
JR015	1-216-296-00	SHORT (CHIP) 0		R112	1-208-810-11	RES,CHIP 15K 2% 1/8W	
JR016	1-216-295-00	SHORT (CHIP) 0		R113	1-208-810-11	RES,CHIP 15K 2% 1/8W	
JR017	1-216-295-00	SHORT (CHIP) 0		R114	1-208-810-11	RES,CHIP 15K 2% 1/8W	
		< COIL >		R115	1-208-810-11	RES,CHIP 15K 2% 1/8W	
L501	1-410-521-11	INDUCTOR 100uH		R116	1-216-210-00	RES,CHIP 3.3K 2% 1/8W	
L502	1-410-521-11	INDUCTOR 100uH		R117	1-216-210-00	RES,CHIP 3.3K 2% 1/8W	
L503	1-410-521-11	INDUCTOR 100uH		R118	1-216-238-00	RES,CHIP 47K 2% 1/8W	
L504	1-410-521-11	INDUCTOR 100uH		R119	1-208-484-11	RES,CHIP 820 2% 1/8W	
L505	1-410-521-11	INDUCTOR 100uH		R120	1-208-510-61	RES,CHIP 10K 2% 1/8W	
L506	1-410-521-11	INDUCTOR 100uH		R121	1-216-174-00	RES,CHIP 100 2% 1/8W	
L507	1-410-502-11	INDUCTOR 2.7uH		R122	1-216-214-00	RES,CHIP 4.7K 2% 1/8W	
L508	1-410-509-11	INDUCTOR 10uH		R123	1-216-210-00	RES,CHIP 3.3K 2% 1/8W	
L510	1-410-517-11	INDUCTOR 47uH		R124	1-208-494-61	RES,CHIP 2.2K 2% 1/8W	
L551	1-410-521-11	INDUCTOR 100uH		R125	1-208-484-11	RES,CHIP 820 2% 1/8W	
L560	1-410-517-11	INDUCTOR 47uH		R126	1-216-202-00	RES,CHIP 1.5K 2% 1/8W	
				R127	1-216-238-00	RES,CHIP 47K 2% 1/8W	
				R128	1-216-238-00	RES,CHIP 47K 2% 1/8W	

The components identified by mark △ or dotted line with mark △ are critical for safety. Replace only with part number specified.	Les composants identifiés par une marque △ sont critiques pour la sécurité. Ne les remplacer que par une pièce portant le numéro spécifié.
--	--

MAIN

Ref. No.	Part No.	Description	Quantity	Unit	Remark	Ref. No.	Part No.	Description	Quantity	Unit	Remark
R129	1-216-178-00	RES,CHIP	150	2%	1/8W	R323	1-216-210-00	RES,CHIP	3.3K	2%	1/8W
R130	1-216-178-00	RES,CHIP	150	2%	1/8W	R324	1-208-494-61	RES,CHIP	2.2K	2%	1/8W
R131	1-208-510-61	RES,CHIP	10K	2%	1/8W	R325	1-208-484-11	RES,CHIP	820	2%	1/8W
R132	1-216-296-00	SHORT (CHIP)	0			R326	1-216-202-00	RES,CHIP	1.5K	2%	1/8W
R151	1-218-233-11	RES,CHIP	47	5%	1/2W	R327	1-216-238-00	RES,CHIP	47K	2%	1/8W
R152	1-216-097-00	RES,CHIP	100K	5%	1/10W	R328	1-216-238-00	RES,CHIP	47K	2%	1/8W
R202	1-216-238-00	RES,CHIP	47K	2%	1/8W	R329	1-216-178-00	RES,CHIP	150	2%	1/8W
R203	1-216-174-00	RES,CHIP	100	2%	1/8W	R330	1-216-178-00	RES,CHIP	150	2%	1/8W
R204	1-208-510-61	RES,CHIP	10K	2%	1/8W	R331	1-208-510-61	RES,CHIP	10K	2%	1/8W
R205	1-208-510-61	RES,CHIP	10K	2%	1/8W	R332	1-216-296-00	SHORT (CHIP)	0		
R206	1-216-214-00	RES,CHIP	4.7K	2%	1/8W	R351	1-218-233-11	RES,CHIP	47	5%	1/2W
R207	1-216-214-00	RES,CHIP	4.7K	2%	1/8W	R402	1-216-238-00	RES,CHIP	47K	2%	1/8W
R208	1-208-510-61	RES,CHIP	10K	2%	1/8W	R403	1-216-174-00	RES,CHIP	100	2%	1/8W
R209	1-208-510-61	RES,CHIP	10K	2%	1/8W	R404	1-208-510-61	RES,CHIP	10K	2%	1/8W
R210	1-208-510-61	RES,CHIP	10K	2%	1/8W	R405	1-208-510-61	RES,CHIP	10K	2%	1/8W
R211	1-208-510-61	RES,CHIP	10K	2%	1/8W	R406	1-216-214-00	RES,CHIP	4.7K	2%	1/8W
R212	1-208-810-11	RES,CHIP	15K	2%	1/8W	R407	1-216-214-00	RES,CHIP	4.7K	2%	1/8W
R213	1-208-810-11	RES,CHIP	15K	2%	1/8W	R408	1-208-510-61	RES,CHIP	10K	2%	1/8W
R214	1-208-810-11	RES,CHIP	15K	2%	1/8W	R409	1-208-510-61	RES,CHIP	10K	2%	1/8W
R215	1-208-810-11	RES,CHIP	15K	2%	1/8W	R410	1-208-510-61	RES,CHIP	10K	2%	1/8W
R216	1-216-210-00	RES,CHIP	3.3K	2%	1/8W	R411	1-208-510-61	RES,CHIP	10K	2%	1/8W
R217	1-216-210-00	RES,CHIP	3.3K	2%	1/8W	R412	1-208-810-11	RES,CHIP	15K	2%	1/8W
R218	1-216-238-00	RES,CHIP	47K	2%	1/8W	R413	1-208-810-11	RES,CHIP	15K	2%	1/8W
R219	1-208-484-11	RES,CHIP	820	2%	1/8W	R414	1-208-810-11	RES,CHIP	15K	2%	1/8W
R220	1-208-510-61	RES,CHIP	10K	2%	1/8W	R415	1-208-810-11	RES,CHIP	15K	2%	1/8W
R221	1-216-174-00	RES,CHIP	100	2%	1/8W	R416	1-216-210-00	RES,CHIP	3.3K	2%	1/8W
R222	1-216-214-00	RES,CHIP	4.7K	2%	1/8W	R417	1-216-210-00	RES,CHIP	3.3K	2%	1/8W
R223	1-216-210-00	RES,CHIP	3.3K	2%	1/8W	R418	1-216-238-00	RES,CHIP	47K	2%	1/8W
R224	1-208-494-61	RES,CHIP	2.2K	2%	1/8W	R419	1-208-484-11	RES,CHIP	820	2%	1/8W
R225	1-208-484-11	RES,CHIP	820	2%	1/8W	R420	1-208-510-61	RES,CHIP	10K	2%	1/8W
R226	1-216-202-00	RES,CHIP	1.5K	2%	1/8W	R421	1-216-174-00	RES,CHIP	100	2%	1/8W
R227	1-216-238-00	RES,CHIP	47K	2%	1/8W	R422	1-216-214-00	RES,CHIP	4.7K	2%	1/8W
R228	1-216-238-00	RES,CHIP	47K	2%	1/8W	R423	1-216-210-00	RES,CHIP	3.3K	2%	1/8W
R229	1-216-178-00	RES,CHIP	150	2%	1/8W	R424	1-208-494-61	RES,CHIP	2.2K	2%	1/8W
R230	1-216-178-00	RES,CHIP	150	2%	1/8W	R425	1-208-484-11	RES,CHIP	820	2%	1/8W
R231	1-208-510-61	RES,CHIP	10K	2%	1/8W	R426	1-216-202-00	RES,CHIP	1.5K	2%	1/8W
R232	1-216-296-00	SHORT (CHIP)	0			R427	1-216-238-00	RES,CHIP	47K	2%	1/8W
R302	1-216-238-00	RES,CHIP	47K	2%	1/8W	R428	1-216-238-00	RES,CHIP	47K	2%	1/8W
R303	1-216-174-00	RES,CHIP	100	2%	1/8W	R429	1-216-178-00	RES,CHIP	150	2%	1/8W
R304	1-208-510-61	RES,CHIP	10K	2%	1/8W	R430	1-216-178-00	RES,CHIP	150	2%	1/8W
R305	1-208-510-61	RES,CHIP	10K	2%	1/8W	R431	1-208-510-61	RES,CHIP	10K	2%	1/8W
R306	1-216-214-00	RES,CHIP	4.7K	2%	1/8W	R432	1-216-296-00	SHORT (CHIP)	0		
R307	1-216-214-00	RES,CHIP	4.7K	2%	1/8W	R501	1-216-025-00	RES,CHIP	100	5%	1/10W
R308	1-208-510-61	RES,CHIP	10K	2%	1/8W	R502	1-216-017-00	RES,CHIP	47	5%	1/10W
R309	1-208-510-61	RES,CHIP	10K	2%	1/8W	R503	1-216-025-00	RES,CHIP	100	5%	1/10W
R310	1-208-510-61	RES,CHIP	10K	2%	1/8W	R504	1-216-025-00	RES,CHIP	100	5%	1/10W
R311	1-208-510-61	RES,CHIP	10K	2%	1/8W	R505	1-216-025-00	RES,CHIP	100	5%	1/10W
R312	1-208-810-11	RES,CHIP	15K	2%	1/8W	R506	1-216-025-00	RES,CHIP	100	5%	1/10W
R313	1-208-810-11	RES,CHIP	15K	2%	1/8W	R507	1-216-214-00	RES,CHIP	4.7K	2%	1/8W
R314	1-208-810-11	RES,CHIP	15K	2%	1/8W	R508	1-208-486-61	RES,CHIP	1K	2%	1/8W
R315	1-208-810-11	RES,CHIP	15K	2%	1/8W	R509	1-216-210-00	RES,CHIP	3.3K	2%	1/8W
R316	1-216-210-00	RES,CHIP	3.3K	2%	1/8W	R510	1-216-025-00	RES,CHIP	100	5%	1/10W
R317	1-216-210-00	RES,CHIP	3.3K	2%	1/8W	R511	1-216-025-00	RES,CHIP	100	5%	1/10W
R318	1-216-238-00	RES,CHIP	47K	2%	1/8W	R512	1-216-025-00	RES,CHIP	100	5%	1/10W
R319	1-208-484-11	RES,CHIP	820	2%	1/8W	R513	1-216-025-00	RES,CHIP	100	5%	1/10W
R320	1-208-510-61	RES,CHIP	10K	2%	1/8W	R517	1-216-017-00	RES,CHIP	47	5%	1/10W
R321	1-216-174-00	RES,CHIP	100	2%	1/8W	R518	1-216-025-00	RES,CHIP	100	5%	1/10W
R322	1-216-214-00	RES,CHIP	4.7K	2%	1/8W	R519	1-216-025-00	RES,CHIP	100	5%	1/10W

MAIN

POWER SWITCH

VOLUME

Ref. No.	Part No.	Description	Quantity	Value	Remark
R520	1-216-025-00	RES,CHIP	100	5%	1/10W
R521	1-216-025-00	RES,CHIP	100	5%	1/10W
R522	1-216-025-00	RES,CHIP	100	5%	1/10W
R523	1-216-025-00	RES,CHIP	100	5%	1/10W
R524	1-216-025-00	RES,CHIP	100	5%	1/10W
R525	1-216-025-00	RES,CHIP	100	5%	1/10W
R526	1-216-025-00	RES,CHIP	100	5%	1/10W
R527	1-216-025-00	RES,CHIP	100	5%	1/10W
R528	1-216-025-00	RES,CHIP	100	5%	1/10W
R529	1-216-025-00	RES,CHIP	100	5%	1/10W
R530	1-216-065-00	RES,CHIP	4.7K	5%	1/10W
R531	1-216-121-00	RES,CHIP	1M	5%	1/10W
R532	1-216-041-00	RES,CHIP	470	5%	1/10W
R533	1-216-041-00	RES,CHIP	470	5%	1/10W
R534	1-216-121-00	RES,CHIP	1M	5%	1/10W
R535	1-216-025-00	RES,CHIP	100	5%	1/10W
R536	1-216-041-00	RES,CHIP	470	5%	1/10W
R537	1-216-053-00	METAL CHIP	1.5K	5%	1/10W
R538	1-216-025-00	RES,CHIP	100	5%	1/10W
R539	1-216-025-00	RES,CHIP	100	5%	1/10W
R540	1-216-073-00	METAL CHIP	10K	5%	1/10W
R542	1-216-073-00	METAL CHIP	10K	5%	1/10W
R551	1-216-025-00	RES,CHIP	100	5%	1/10W
R552	1-216-017-00	RES,CHIP	47	5%	1/10W
R553	1-216-025-00	RES,CHIP	100	5%	1/10W
R554	1-216-025-00	RES,CHIP	100	5%	1/10W
R555	1-216-025-00	RES,CHIP	100	5%	1/10W
R556	1-216-025-00	RES,CHIP	100	5%	1/10W
R557	1-216-214-00	RES,CHIP	4.7K	2%	1/8W
R558	1-208-486-61	RES,CHIP	1K	2%	1/8W
R559	1-216-210-00	RES,CHIP	3.3K	2%	1/8W
R560	1-216-025-00	RES,CHIP	100	5%	1/10W
R561	1-216-025-00	RES,CHIP	100	5%	1/10W
R562	1-216-025-00	RES,CHIP	100	5%	1/10W
R563	1-216-025-00	RES,CHIP	100	5%	1/10W
R651	1-216-081-00	METAL CHIP	22K	5%	1/10W
R652	1-216-065-00	RES,CHIP	4.7K	5%	1/10W
R653	1-216-097-00	RES,CHIP	100K	5%	1/10W
R702	1-216-033-00	METAL CHIP	220	5%	1/10W
R703	1-216-033-00	METAL CHIP	220	5%	1/10W
R704	1-216-061-00	METAL CHIP	3.3K	5%	1/10W
R705	1-216-073-00	METAL CHIP	10K	5%	1/10W
R706	1-216-089-00	RES,CHIP	47K	5%	1/10W
R707	1-216-097-00	RES,CHIP	100K	5%	1/10W
R708	1-216-097-00	RES,CHIP	100K	5%	1/10W
R709	1-216-089-00	RES,CHIP	47K	5%	1/10W
R710	1-216-121-00	RES,CHIP	1M	5%	1/10W
R711	1-216-089-00	RES,CHIP	47K	5%	1/10W
R712	1-216-049-11	RES,CHIP	1K	5%	1/10W
R713	1-216-073-00	METAL CHIP	10K	5%	1/10W
R716	1-216-073-00	METAL CHIP	10K	5%	1/10W
R717	1-216-073-00	METAL CHIP	10K	5%	1/10W
R718	1-216-073-00	METAL CHIP	10K	5%	1/10W
R719	1-216-073-00	METAL CHIP	10K	5%	1/10W
R720	1-216-073-00	METAL CHIP	10K	5%	1/10W
R721	1-216-073-00	METAL CHIP	10K	5%	1/10W
R722	1-216-129-00	METAL CHIP	2.2M	5%	1/10W

Ref. No.	Part No.	Description	Quantity	Value	Remark
R723	1-216-017-00	RES,CHIP	47	5%	1/10W
R724	1-216-017-00	RES,CHIP	47	5%	1/10W
R725	1-216-073-00	METAL CHIP	10K	5%	1/10W
R726	1-216-073-00	METAL CHIP	10K	5%	1/10W
R727	1-216-067-00	METAL CHIP	5.6K	5%	1/10W
R728	1-216-049-11	RES,CHIP	1K	5%	1/10W
R729	1-216-025-00	RES,CHIP	100	5%	1/10W
R730	1-216-025-00	RES,CHIP	100	5%	1/10W
R731	1-216-073-00	METAL CHIP	10K	5%	1/10W
R732	1-216-073-00	METAL CHIP	10K	5%	1/10W
R733	1-216-073-00	METAL CHIP	10K	5%	1/10W
R734	1-216-073-00	METAL CHIP	10K	5%	1/10W
R735	1-216-073-00	METAL CHIP	10K	5%	1/10W
R736	1-216-025-00	RES,CHIP	100	5%	1/10W
R737	1-216-025-00	RES,CHIP	100	5%	1/10W
R738	1-216-049-11	RES,CHIP	1K	5%	1/10W
R739	1-218-283-11	RES,CHIP	27	5%	1/2W
R740	1-216-065-00	RES,CHIP	4.7K	5%	1/10W
R751	1-216-033-00	METAL CHIP	220	5%	1/10W
R752	1-216-033-00	METAL CHIP	220	5%	1/10W
R753	1-216-033-00	METAL CHIP	220	5%	1/10W
R754	1-216-033-00	METAL CHIP	220	5%	1/10W
R755	1-216-073-00	METAL CHIP	10K	5%	1/10W
R756	1-216-073-00	METAL CHIP	10K	5%	1/10W
R757	1-216-049-11	RES,CHIP	1K	5%	1/10W
< VARIABLE RESISTOR >					
RV701	1-225-603-21	RES, VAR 1K (LCD CONTRAST)			
< SWITCH >					
S101	1-571-658-11	SWITCH, SLIDE (INPUT LEVEL)			
S102	1-571-658-11	SWITCH, SLIDE (OUTPUT LEVEL)			
< VIBRATOR >					
X501	1-578-667-11	VIBRATOR, CRYSTAL (49.152MHz)			
X701	1-577-358-21	VIBRATOR, CERAMIC (4MHz)			

*	1-668-989-11	POWER SWITCH BOARD			

< CAPACITOR >					
△C601	1-117-703-11	CERAMIC	0.0047uF	99%	250V
< CONNECTOR >					
CN603	1-770-550-11	PIN, CONNECTOR (PC BOARD) 2P			
< SWITCH >					
△S601	1-572-267-51	SWITCH, PUSH (AC POWER)(1 KEY) (ON/OFF)			

*	1-668-987-11	VOLUME BOARD			

< CAPACITOR >					
C801	1-164-159-11	CERAMIC	0.1uF		50V
C901	1-136-153-00	FILM	0.01uF	5%	50V
(DPS-V55)					

<p>The components identified by mark △ or dotted line with mark △ are critical for safety. Replace only with part number specified.</p>	<p>Les composants identifiés par une marque △ sont critiques pour la sécurité. Ne les remplacer que par une pièce portant le numéro spécifié.</p>
---	---

VOLUME

Ref. No.	Part No.	Description	Remark
C960	1-126-022-11	ELECT 47uF 20% 25V	(DPS-V55M)
< CONNECTOR >			
CN151	1-564-523-11	PLUG, CONNECTOR 8P	
* CN351	1-564-521-11	PLUG, CONNECTOR 6P	
CN901	1-766-798-11	CONNECTOR, BOARD TO BOARD 5P	(DPS-V55M)
< DIODE >			
D801	8-719-025-62	LED SML1216W (INPUT LEVEL 1)	
D802	8-719-025-62	LED SML1216W (INPUT LEVEL 2)	
D803	8-719-025-62	LED SML1216W (INPUT LEVEL 3)	
D804	8-719-025-62	LED SML1216W (INPUT LEVEL 4)	
< IC >			
IC901	8-759-711-35	IC NJM4580D	
IC902	8-759-711-35	IC NJM4580D	
< TRANSISTOR >			
Q801	8-729-422-57	TRANSISTOR UN4111	
Q802	8-729-422-57	TRANSISTOR UN4111	
Q803	8-729-422-57	TRANSISTOR UN4111	
Q804	8-729-422-57	TRANSISTOR UN4111	
Q805	8-729-422-57	TRANSISTOR UN4111	
Q806	8-729-422-57	TRANSISTOR UN4111	
Q807	8-729-422-57	TRANSISTOR UN4111	
Q808	8-729-422-57	TRANSISTOR UN4111	
< RESISTOR >			
R801	1-249-409-11	CARBON 220 5% 1/4W	
R802	1-249-411-11	CARBON 330 5% 1/4W	
R803	1-249-409-11	CARBON 220 5% 1/4W	
R804	1-249-411-11	CARBON 330 5% 1/4W	
R805	1-249-409-11	CARBON 220 5% 1/4W	
R806	1-249-411-11	CARBON 330 5% 1/4W	
R807	1-249-409-11	CARBON 220 5% 1/4W	
R808	1-249-411-11	CARBON 330 5% 1/4W	
R901	1-259-436-11	CARBON 2.2K 5% 1/6W	
R902	1-259-436-11	CARBON 2.2K 5% 1/6W	
R903	1-259-436-11	CARBON 2.2K 5% 1/6W	
R904	1-259-436-11	CARBON 2.2K 5% 1/6W	
R905	1-259-436-11	CARBON 2.2K 5% 1/6W	
R906	1-259-436-11	CARBON 2.2K 5% 1/6W	
R907	1-259-436-11	CARBON 2.2K 5% 1/6W	
R908	1-259-436-11	CARBON 2.2K 5% 1/6W	
R960	1-259-468-11	CARBON 47K 5% 1/6W	(DPS-V55M)
< VARIABLE RESISTOR >			
RV901	1-223-673-11	RES, VAR, CARBON 10K (INPUT LEVEL 1)	
RV902	1-223-673-11	RES, VAR, CARBON 10K (INPUT LEVEL 2)	
RV903	1-223-673-11	RES, VAR, CARBON 10K (INPUT LEVEL 3)	
RV904	1-223-673-11	RES, VAR, CARBON 10K (INPUT LEVEL 4)	
< SWITCH >			
S901	1-572-625-11	SWITCH, SLIDE (REAR, CH-1, CH-1+2)	(DPS-V55M)

Ref. No.	Part No.	Description	Remark
MISCELLANEOUS *****			
9	1-773-178-11	WIRE (FLAT TYPE) (23 CORE)	
* 55	1-668-990-11	POWER COVER BOARD	
△57	1-575-651-21	CORD, POWER (DPS-V55M)	
△57	1-590-836-11	CORD, POWER (DPS-V55)	
△T601	1-431-768-11	TRANSFORMER, POWER (DPS-V55M)	
△T601	1-431-769-11	TRANSFORMER, POWER (DPS-V55)	*****
***** HARDWARE LIST *****			
#1	7-685-647-79	SCREW +BVTP 3X10 TYPE2 N-S	
#2	7-685-871-09	SCREW +BVTT 3X6 (S)	
#3	7-685-871-01	SCREW +BVTT 3X6 (S)	
#4	7-621-771-06	SCREW, LOCK	*****
***** ACCESSORIES & PACKING MATERIALS *****			
3-862-747-11		MANUAL, INSTRUCTION (GERMAN) (AEP)	
3-862-747-21		MANUAL, INSTRUCTION (ENGLISH, FRENCH)	
3-862-760-11		GUIDE, PARAMETER	
3-862-761-11		LIST, PRESET	

The components identified by mark △ or dotted line with mark △ are critical for safety. Replace only with part number specified.	Les composants identifiés par une marque △ sont critiques pour la sécurité. Ne les remplacer que par une pièce portant le numéro spécifié.
--	--